

Open kinematic chains (kinematics)

David Mauricio Alba Lucero
José Luis Pérez Díaz
Ignacio Valiente Blanco
Efrén Díez Jiménez



Universidad
Carlos III de Madrid





Kinematic modeling of manipulator arms

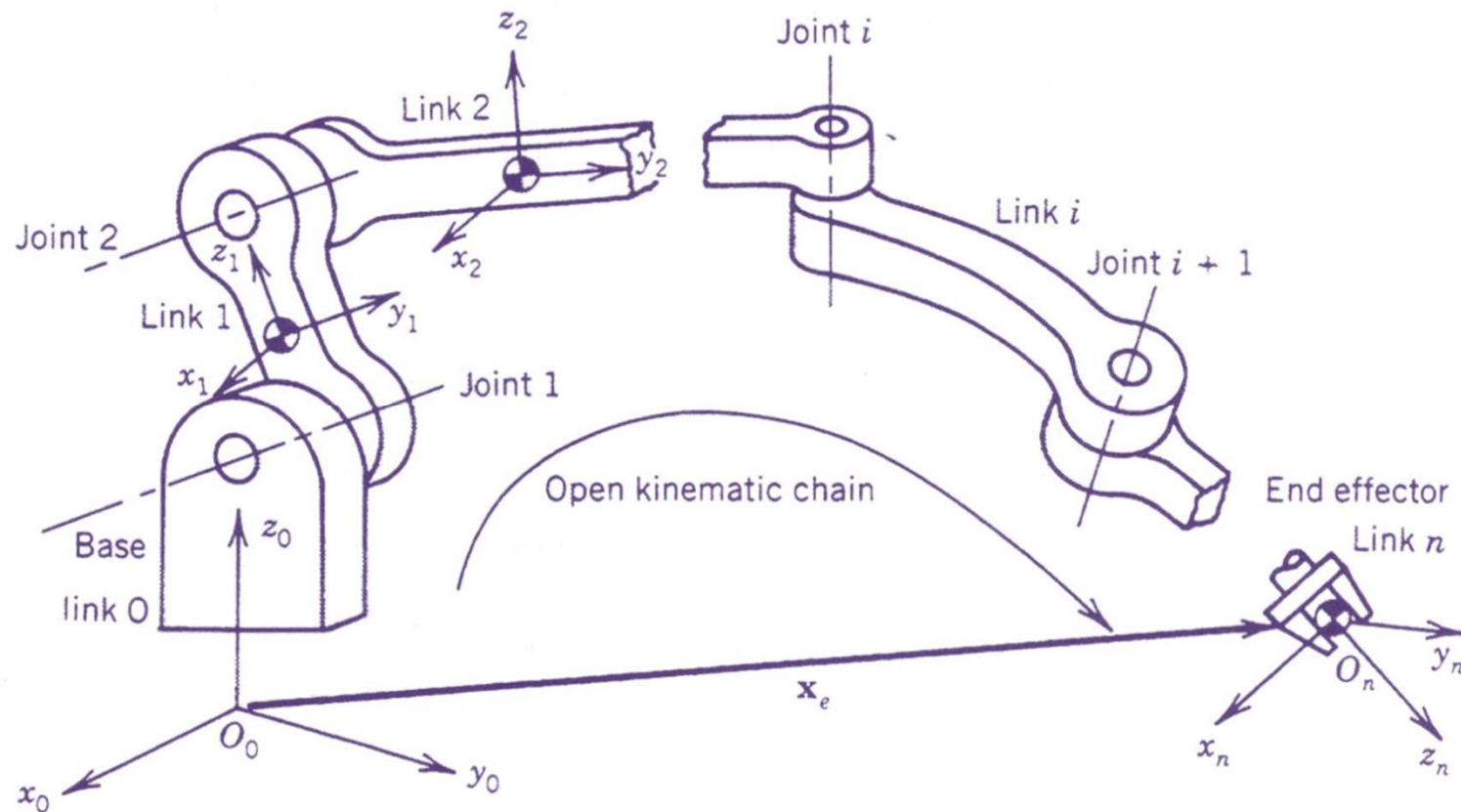



Denavit-Hartenberg notation

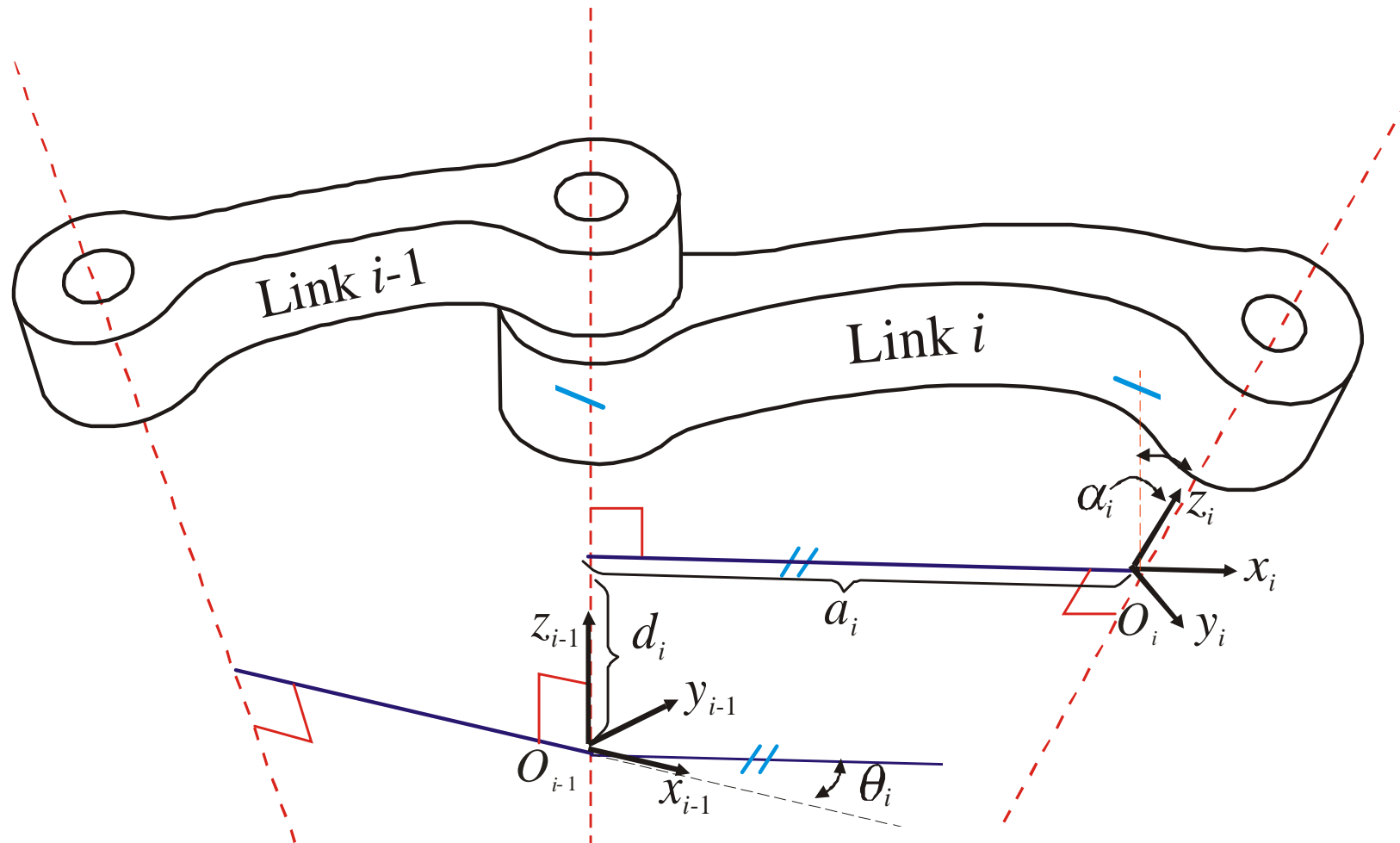



Denavit-Hartenberg notation

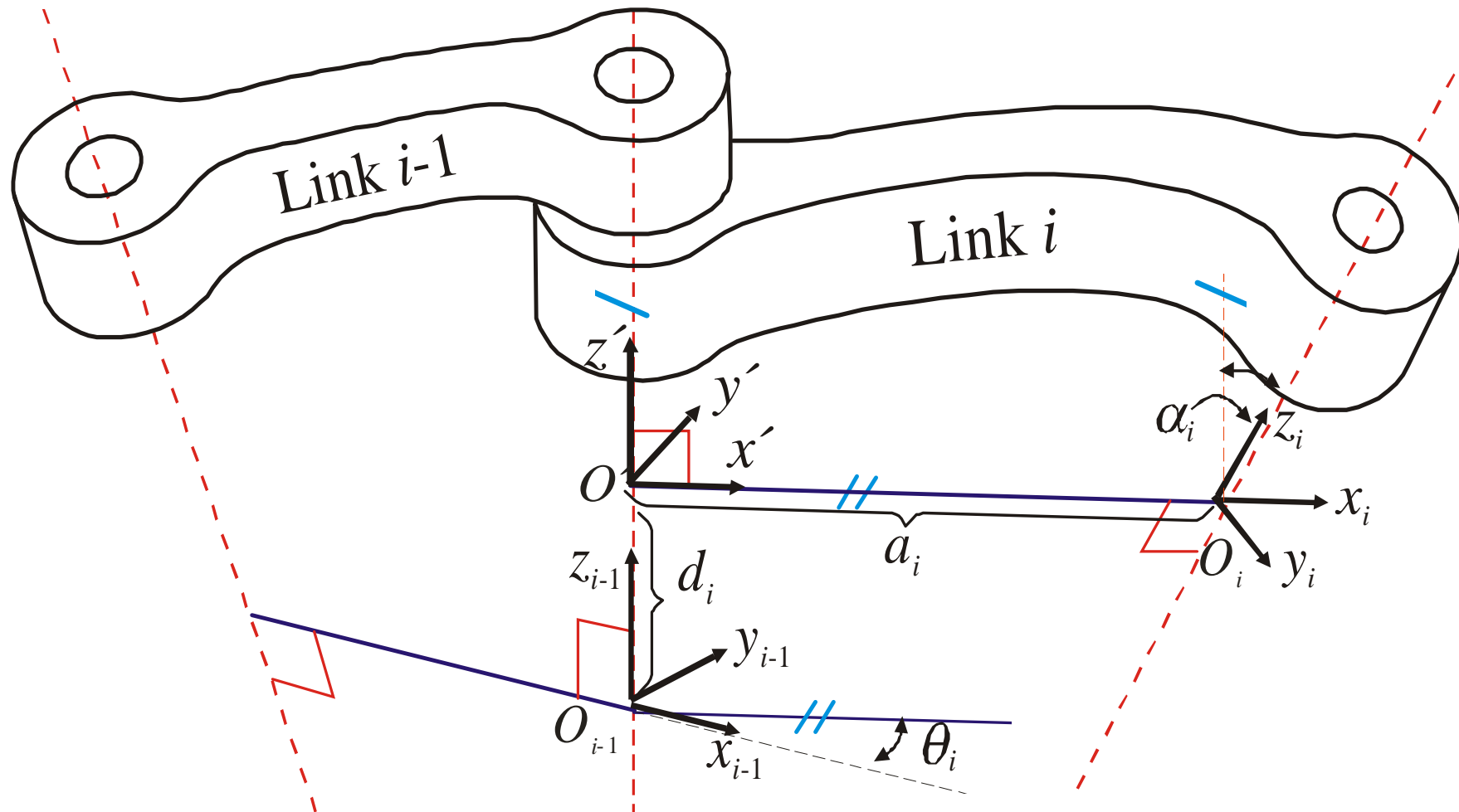



Kinematic modeling of manipulator arms

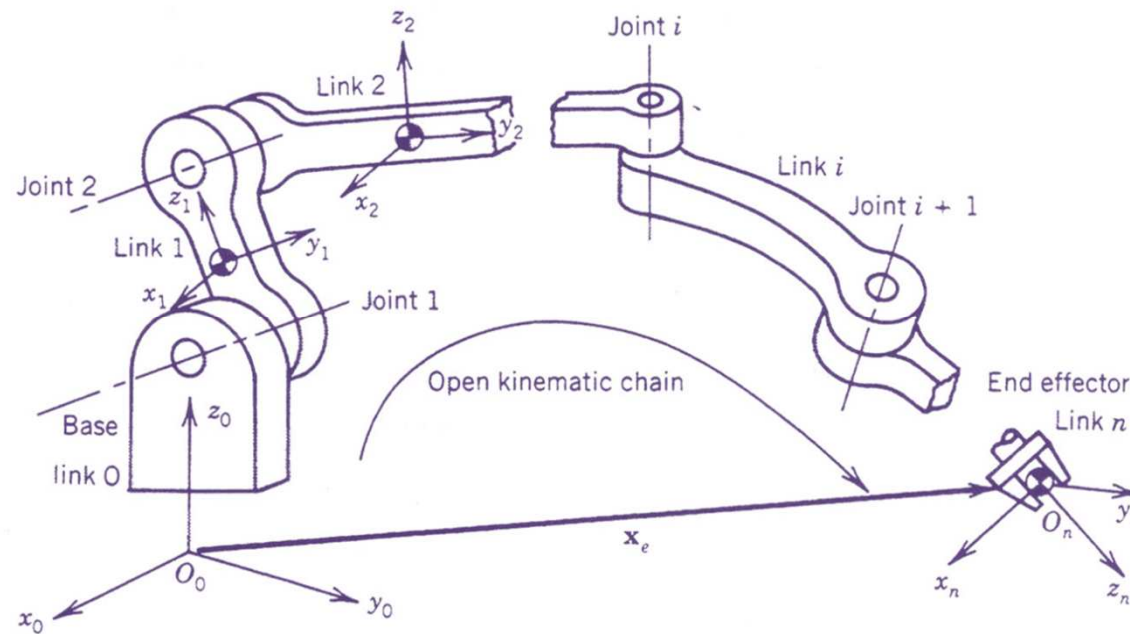



Kinematic modeling of manipulator arms

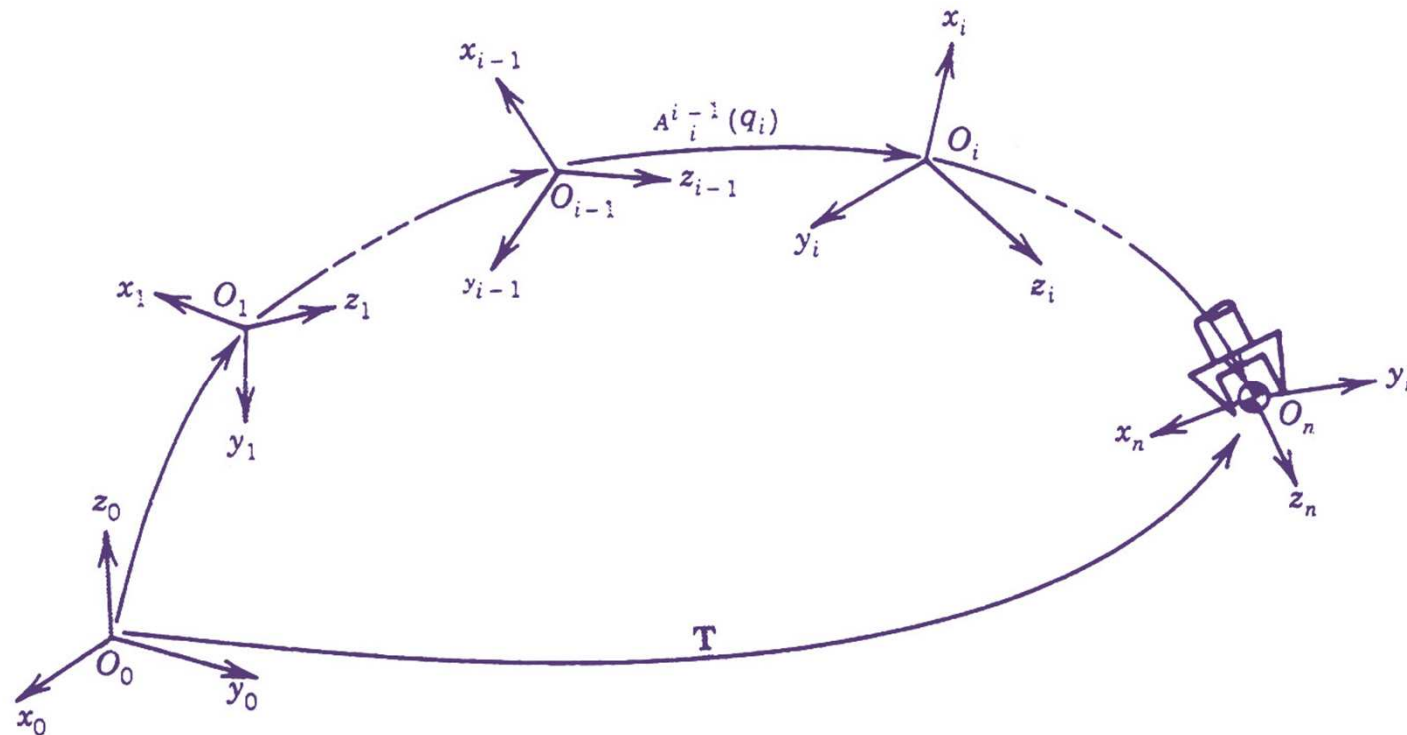



Kinematic modeling of manipulator arms

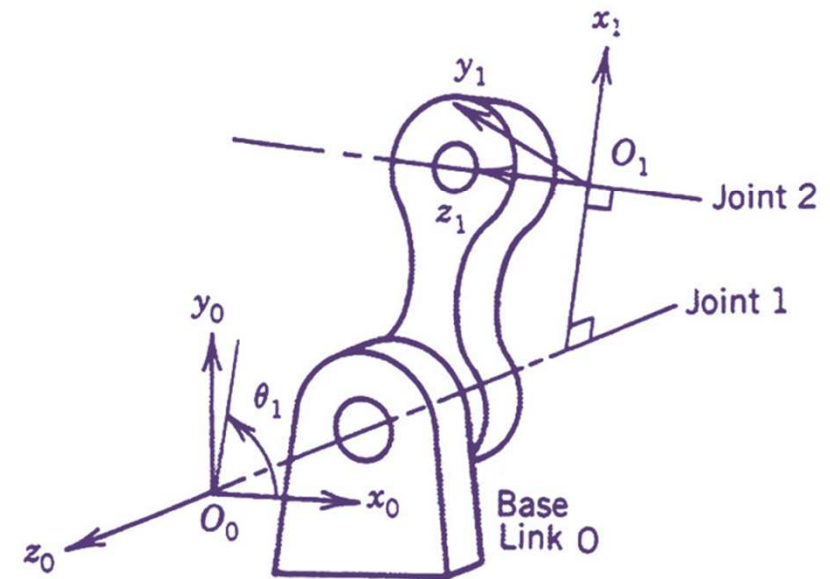
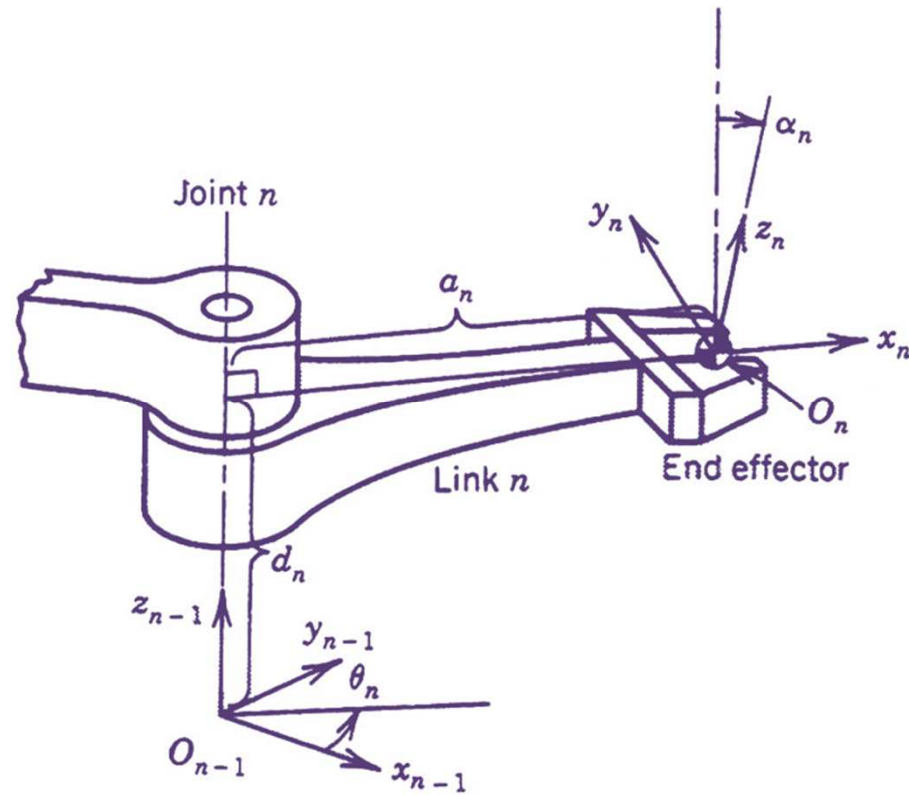



Example

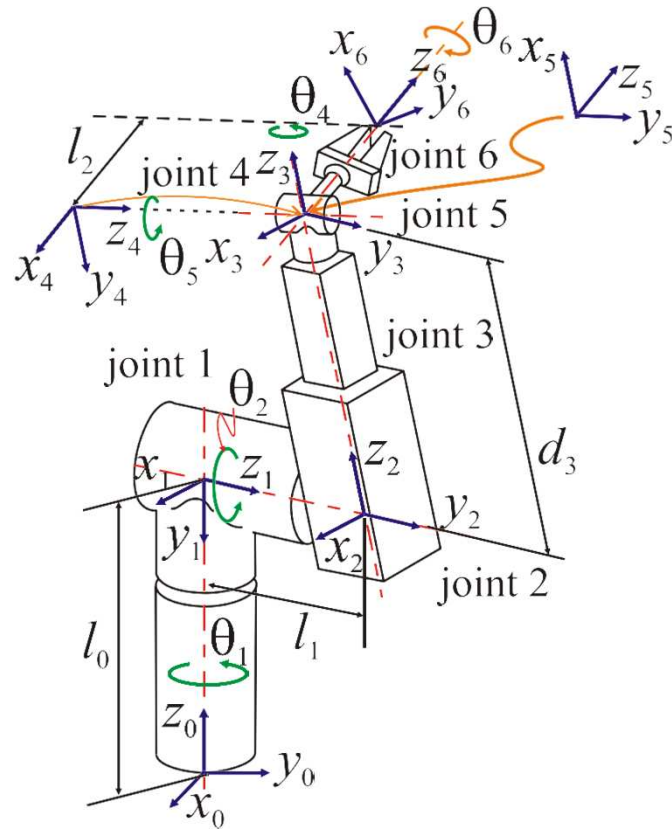



References

- Asada H. and Slotine, J. Robot Analysis and control.
- Spong, Mark. Robot control.