

UNIVERSIDAD CARLOS III DE MADRID

# Ejercicios de evaluación. Grafos de dependencias y DLX

---

Departamento de Ingeniería de Sistemas y  
Automática

RAÚL PÉRULA MARTÍNEZ  
LUIS ENRIQUE MORENO LORENTE  
ALBERTO BRUNETE GONZALEZ  
CESAR AUGUSTO ARISMENDI GUTIERREZ  
DOMINGO MIGUEL GUINEA GARCIA ALEGRE  
JOSÉ CARLOS CASTILLO MONTOYA



Universidad  
Carlos III de Madrid



Esta obra se publica bajo una licencia Creative Commons Reconocimiento-NoComercial-CompartidIgual 3.0 España.



## Ejercicio 1

Se dispone de un procesador que está segmentado en las siguientes etapas: Búsqueda, decodificación, emisión, ejecución y write-back. Dispone de cuatro unidades funcionales de ejecución: una para operaciones en punto flotante (2 ciclos), una para operaciones enteras (1 ciclo) , una para lectura en memoria y otra para escritura en memoria (1 ciclo). Dado el siguiente programa en ensamblador:

1. bucle: ld f2, 0(r1)
2.        add f4, f0, f2
3.        sto 0(r1), f4
4.        ld f6, -4(r1)
5.        add f8, f6, f2
6.        sto -4(r1), f8
7.        sub r1, r1, #8
8.        bnez r1, bucle

Se pide:

- 1) Cronograma de ejecución sin adelantamiento. Calcular el CPI.
- 2) Cronograma de ejecución con adelantamiento. Calcular el CPI.



Sin delantamiento	1	2	3	4	5	6	7	8	9	10	11	12	13	14	15	16	17	18	19	20	21	22	23	24	25	26	27	28	
1. bucle:	ld	2	,	r1	f	d	x	m	w																				
2.	add	4	,	f0	,	f2	f	-	-	d	x	x	m	w															
3.	sto	(	r1	,	4	f	-	-	-	d	x	m	w																
4.	ld	6	,	4	(	r1	f	d	x	m	w																		
5.	add	8	,	6	,	2	f	-	-	-	d	x	m	w															
6.	sto	4	(	r1	,	8	f	-	-	-	d	x	m	w															
7.	sub	1	,	r1	,	8	f	d	x	m	w																		
8.	bnez	1	,	bucle	f	-	-	-	d	x	m	w																	

**CPI = 24/8 = 3**

Con delantamiento	1	2	3	4	5	6	7	8	9	10	11	12	13	14	15	16	17	18	19	20	21	22	23	24	25	26	27	28	
1. bucle:	ld	2	,	r1	f	d	x	m	*	w																			
2.	add	4	,	f0	,	f2	f	d	-	*	x	*	m	w															
3.	sto	(	r1	,	4	f	-	d	-	*	x	m	w																
4.	ld	6	,	4	(	r1	f	-	d	x	m	*	w																
5.	add	8	,	6	,	2	f	d	-	*	x	*	m	w															
6.	sto	4	(	r1	,	8	f	-	d	-	*	x	m	w															
7.	sub	1	,	r1	,	8	f	-	d	x	*	m	w																
8.	bnez	1	,	bucle	f	d	*	x	m	w																			

**CPI = 16/8 = 2**



## Ejercicio 2

Suponiendo que se tiene el siguiente código en lenguaje ensamblador

```
L0:   ld r3, # 100
      ld r2, DIR_X
      ld r2, DIR_Y
1 L1:   ld f2, 0(r1)
2      blt f2, 0 , L3
3 L2:   ld f4, 0(r2)
4      ld f6, 4(r2)
5      add f8, f2, f4
6      add f8, f8, f6
7      store 0(r2), f8
8      br L4
9 L3:   store 0(r2), f2
10 L4:  add r1, r1, #4
11      add r2, r2, #4
12      sub r3,r3, #4
13      blt r3, 0 L1
```

donde se lista en primer lugar el operando de destino y a continuación los operandos fuentes, y en el caso de las instrucciones de salto se listan primero los operandos a ser comparados y después la dirección del salto. Se pide:

- 1) Dado el esquema de arquitectura DLX mostrar los cronogramas de ejecución si el control de riesgos se realiza por software (introduciendo instrucciones no-op).
- 2) Obtener los cronogramas suponiendo que la arquitectura del procesador incluye hw para interbloqueo y forwarding.



NO-OP		1	2	3	4	5	6	7	8	9	10	11	12	13	14	15	16	17	18	19	20	21	22	23	24	25	26	27	28	29	30	31						
	<b>S!(r1)&gt;0</b>																																					
	L0:0																																					
	ld3,IR00																																					
	ld2,DIR_X																																					
	ld2,DIR_Y																																					
1	L1:0		F	D	X	M	W																															
	NOP		F	D																																		
	NOP		F	D																																		
2	blt2,IR3		F	D	X	M	W																															
	NOP		F	D																																		
	NOP		F	D																																		
	NOP		F	D																																		
3	L2:		F	D	X	M	W																															
	ld4,(r2)		F	D	X	M	W																															
4	ld6,(r2)		F	D	X	M	W																															
	NOP		F	D																																		
5	add8,IR4		F	D	X	M	W																															
	NOP		F	D																																		
	NOP		F	D																																		
6	add8,IR6		F	D	X	M	W																															
	NOP		F	D																																		
	NOP		F	D																																		
7	store(r2),IR8		F	D	X	M	W																															
8	br4		F	D	X	M	W																															
	NOP		F	D	X	M	W																															
	NOP		F	D																																		
	NOP		F	D																																		
9	L3:		F	D	X	M	W																															
	store(r2),IR2		F	D	X	M	W																															
10	L4:0		F	D	X	M	W																															
	add1,IR4		F	D	X	M	W																															
	add2,IR2,IR4		F	D	X	M	W																															
	sub3,r3,IR4		F	D	X	M	W																															
	NOP		F	D																																		
	NOP		F	D																																		
13	blt3,IR1		F	D	X	M	W																															



INTERBLOQUEO FORWARDING

	1	2	3	4	5	6	7	8	9	10	11	12	13	14	15	16	17	18	19	20	21	22	23	
1 L1:																								
2	F	D	X	M*	W																			
3 L2:																								
4	F	-	D	*X	M	W																		
5							F	D	X	M*	W													
6							F	D	X	M*	W													
7							F	D	*X*	M	W													
8							F	D	*X	M	W													
9 L3:							F	D	X	M	W													
10 L4:																								
11																								
12																								
13																								

### Ejercicio 3

El siguiente fragmento de código aplica un filtro sobre un vector A y almacena el resultado en un vector B:

```
for (int i = 1 ; i < 100 ; i++)  
{  
    b[i] = d * a[i-1] + a[i] + d * a[i+1];  
}
```

El compilador lo traduce al siguiente código DLX

	addi r3, r1, 800	; condición de final
	addi r1, r1, 8	; inicialización de los índices
	addi r2, r2, 8	
	ld f0, d	; Carga el coeficiente d
1.	loop ld f2, -8(r1)	; carga de a[i-1]
2.	ld f4, 0(r1)	; carga de a[i]
3.	ld f6, 8(r1)	; carga de a[i+1]
4.	multd f8, f2, f2	; d * a[i-1]
5.	multd f10, f0, f6	; d * a[i+1]
6.	addd f4, f4, f8	; d * a[i-1] + a[i]
7.	addd f4, f4, f10	; d * a[i-1] + a[i] + d * a[i+1]
8.	sd 0(r2), f4	; Guarda en b[i]
9.	addi r2, r2, 8	; incremento de índices
10.	addi r1, r1, 8	
11.	addi r1, r1, 8	
12.	slt r4, r1, r3	
13.	bnez r4, loop	

Las operaciones de división/multiplicación en punto flotante tienen un retardo de 4 ciclos y las operaciones de carga y almacenamiento utilizan la memoria de datos durante 2 ciclos para completar las lecturas y escrituras.

- 1) Dibujar el grafo de dependencias de este programa
- 2) Cronograma de ejecución con y sin adelantamiento. Calcular el CPI para ambas alternativas.



Interbloqueo	in	del	ant	lam	amiento	1	2	3	4	5	6	7	8	9	10	11	12	13	14	15	16	17	18	19	20	21	22	23	24	25	26	27	28	29	30	31	32	33	34	35								
	addi	3,	1,	0																																												
	addi	1,	1,	0																																												
	addi	2,	2,	0																																												
	ld	0,	0																																													
1.	loop	ld	2,	8(r1)		F	D	X	M	M	W																																					
2.		ld	4,	0(r1)		F	D	X	-	M	M	W																																				
3.		ld	6,	0(r1)		F	D	-	X	-	M	M	W																																			
4.		multd	8,	2,2		F	-	D	X	M	X	M	W																																			
5.		multd	10,	0,6		F	-	-	-	D	X	M	X	M	W																																	
6.		addd	4,	4,8		F	-	-	-	D	X	-	M	W																																		
7.		addd	4,	4,10		F	-	-	-	D	X	M	W																																			
8.		sd	0,	2),4		F	-	-	-	D	X	M	W																																			
9.		addi	2,	2,8		F	-	-	-	D	X	M	W																																			
10.		addi	1,	1,8		F	D	X	-	M	W																																					
11.		addi	1,	1,8		F	D	-	X	M	W																																					
12.		slt	4,	1,3		F	-	-	-	D	X	M	W																																			
13.		bnez	4,	loop		F	-	-	-	D	X	M	W																																			





Interbloqueo  
 Adelantamiento

	1	2	3	4	5	6	7	8	9	10	11	12	13	14	15	16	17	18	19	20	21	22	23
1. loop	F	D	X	M	M	W																	
2. ld r4, r1	F	D	X	-	M	M	W																
3. ld r6, r1	F	D	-	X	-	M	M*	W															
4. multd r8, r2, r2	F	-	D	-	X	m	X	m	X	m	X	m	M	W									
5. multd r10, r0, r6	F	-	D	-	X	n	X	m	X	m	X	m	M	W									
6. add r4, r4, r8	F	D	-	*X	M	W																	
7. add r4, r4, r10	F	-	-	D	*X	M	W																
8. sd(r2), r4	F	D	*X	M	M	W																	
9. addi r2, r2, r8	F	D	X	-	M	W																	
10. addi r1, r1, r8	F	D	-	X*	M	W																	
11. addi r1, r1, r8	F	-	D	*X	M	W																	
12. slt r4, r1, r3	F	D	*X	M	W																		
13. bnez r4, r4, loop	F	D	*X	M	W																		

## Ejercicio 4

Dado el código ensamblador que implementa la operación vectorial

$$Y = (a * X + Y) / X:$$

```

        ld r1, dir_x
        ld r2, dir_y
        ld r4, dir_cont
        ld f0, dir_a
1.   loop: ld f2, 0(r1)           ; carga X[i]
2.         multd f4, f2, f0       ; multiplica a * X[i]
3.         ld f6, 0(r2)          ; carga Y[i]
4.         addd f6, f4, f6        ; suma a * X[i] + Y[i]
5.         divd f6, f6, f2        ; Divide (a * X[i] + Y[i]) / X[i]
6.         sd 0(r2), f6          ; Almacena Y[i]
7.         addi r1, r1, 8         ; incrementa el índice de x
8.         addi r2, r2, 8         ; incrementa el índice de Y
9.         sgt r3, r1, r4        ; comprueba si fin
10.        bequz r3, loop

```

Considerando que el código se ejecuta en una máquina DLX segmentada con unidades funcionales con las siguientes características:

Unidad funcional	Latencia (ciclos)
ALU entera	0
Suma PF	1
Multiplicación PF	2
División PF	3

- 1) Obtener el cronograma de una iteración del bucle considerando interbloqueo. Calcular el CPI.
- 2) Obtener el cronograma de una iteración del bucle considerando interbloqueo y anticipación. Calcular el CPI y el speedup respecto al apartado anterior.



INTERBLOQUEO	1	2	3	4	5	6	7	8	9	10	11	12	13	14	15	16	17	18	19	20	21	22	23	24	25	26	27	28	29	
	ld <sub>1</sub> , <sub>1</sub> ir_x																													
	ld <sub>2</sub> , <sub>1</sub> ir_y																													
	ld <sub>4</sub> , <sub>1</sub> ir_cont																													
	ld <sub>0</sub> , <sub>1</sub> ir_a																													
1.	loop: ld <sub>2</sub> , <sub>0</sub> (r1)	F	D	X	M	W																								
2.	multd <sub>4</sub> , <sub>2</sub> , <sub>0</sub>	F	-	-	D	Xm	Xm	Xm	M	W																				
3.	ld <sub>6</sub> , <sub>0</sub> (r2)	F	D	X	M	W																								
4.	add <sub>6</sub> , <sub>4</sub> , <sub>6</sub>	F	-	-	D	Xa	Xa	M	W																					
5.	divd <sub>6</sub> , <sub>6</sub> , <sub>2</sub>	F	-	-	-	D <sub>2</sub>	Xd	Xd	Xd	M	W																			
6.	sd <sub>0</sub> (r2), <sub>6</sub>	F	-	-	-	-	-	-	-	D	X	M	W																	
7.	addi <sub>1</sub> , <sub>1</sub> , <sub>8</sub>	F	D	X	M	W																								
8.	addi <sub>2</sub> , <sub>2</sub> , <sub>8</sub>	F	D	X	M	W																								
9.	sgt <sub>3</sub> , <sub>1</sub> , <sub>4</sub>	F	-	-	D	X	M	W																						
10.	bequz <sub>3</sub> , <sub>3</sub> loop	F	-	-	-	-	-	-	-	D	X	M	W																	

CPI = 29/10 = 2,9

ANTICIPACIÓN

1.	loop:	1	2	3	4	5	6	7	8	9	10	11	12	13	14	15	16	17	18	19	20
2.	ld <sub>2</sub> , <sub>0</sub> (r1)	F	D	X	M	W															
3.	multd <sub>4</sub> , <sub>2</sub> , <sub>0</sub>	F	-	D	*Xn	Xm	M	W													
4.	ld <sub>6</sub> , <sub>0</sub> (r2)	F	D	X	M	W															
5.	add <sub>6</sub> , <sub>4</sub> , <sub>6</sub>	F	-	D	*Xa	Xa	M	W													
6.	divd <sub>6</sub> , <sub>6</sub> , <sub>2</sub>	F	-	D	*Xd	Xd	Xd	*M	W												
7.	sd <sub>0</sub> (r2), <sub>6</sub>	F	-	-	-	-	-	D	*X	M	W										
8.	addi <sub>1</sub> , <sub>1</sub> , <sub>8</sub>	F	D	X	M	W															
9.	addi <sub>2</sub> , <sub>2</sub> , <sub>8</sub>	F	D	X	M	W															
10.	sgt <sub>3</sub> , <sub>1</sub> , <sub>4</sub>	F	D	*X	M	W															
	bequz <sub>3</sub> , <sub>3</sub> loop	F	D	*X	M	W															

CPI = 20/10 = 2



## Ejercicio 5

Suponiendo que el siguiente código en C

```

for ( i = 0; i<100; i++)
    if (X[i ]> 0)
        Y[i]= X[i ]*X[i] -Y[i];
    else
        Y[i]= X[i]*X[i]-Y[i+1]+10;
    
```

tiene la siguiente traducción a un cierto lenguaje ensamblador

```

L0:  ld    r3, #100
      ld    r1,DIR_X
      ld    r2,DIR_Y
1  L1:  ld    f2, 0(r1)
2      mul  f4, f2, f2
3      blt  f2, 0, L3
4  L2:  ld    f6, 0(r2)
5      sub  f6, f4, f6
6      store 0(r2), f6
7      br   L4
8  L3:  ld    f8, 4(r2)
9      sub  f6, f4, f8
10     addi  f4,f6, #10
11     store 0(r2), f4
12  L4:  add  r1, r1, #4
13     add  r2, r2, #4
14     sub  r3, r3, #-1
15     blt  r3, 0, L1
    
```

Los saltos se resuelven en la primera mitad de la etapa Mem y las instrucciones pueden leerse en la segunda mitad de la etapa If. La arquitectura del procesador es la siguiente (DLX, predict-not-taken):

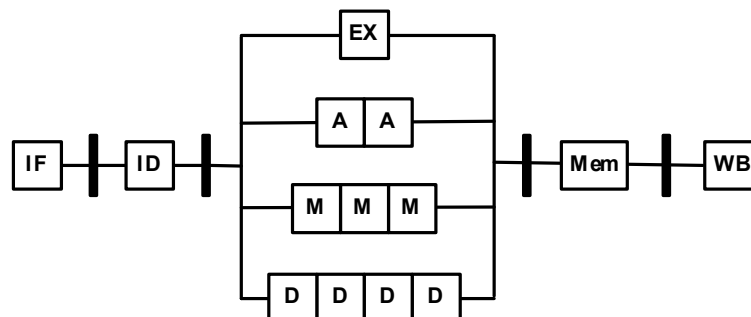



- 1) Muestre el cronograma de la ejecución de una iteración del bucle considerando que los riesgos de datos se resuelven utilizando interbloqueo y que sí se cumple la condición del IF. Calcule el CPI del programa.
- 2) Muestre el cronograma de la ejecución de una iteración del bucle considerando que los riesgos de datos se resuelven utilizando interbloqueo y anticipación, y que sí se cumple la condición del IF. Calcule el CPI del programa.
- 3) Sugiera una posible reorganización del código que suponga una mejora en el CPI del programa e indique la modificación en el cronograma.



SIN DELANTAMIENTO		1	2	3	4	5	6	7	8	9	10	11	12	13	14	15	16	17	18	19	20	21	22	23	24	25	26	27	
L0:	ld																												
	ld																												
	ld																												
1 L1:	ld	F	D	X	M	W																							
2	mul	F	-	-	D	Xm	Xm	Xm	M	W																			
3	blt				F	D	X	M	W																				
4 L2:	ld				F	D	X	-	M	W																			
5	sub				F	-	-	-	D	Xa	Xa	M	W																
6	store				F	-	-	-	D	X	X	M	W																
7	br				L4					F	D	X	M	W															
8 L3:	ld				f8,																								
9	sub				f6,																								
10	addi				f4,																								
11	store				0(r2),																								
12 L4:	add				r1,																F	D	X	M	W				
13	add				r2,																F	D	X	M	W				
14	sub				r3,																F	D	X	M	W				
15	blt				r3,																F	-	-	D	X	M	W		

CPI = 27/11 = 2,45



CONDELANTAMIENTO		1	2	3	4	5	6	7	8	9	10	11	12	13	14	15	16	17	18	19	20	21	
1 L1:	ld	f2,0(r1)	F	D	X	M*	W																
2	mul	f4,2,2	F	-	D	*XrXmXmM	W																
3	blt	f2,0,3	F	D	X	M	W																
4 L2:	ld	f6,0(r2)	F	D	X	-	M*W																
5	sub	f6,4,6	F	-	-	D	*XeXa*M	W															
6	store	0(r2),6	F	-	D	*X	M	W															
7	br	L4	F	D	X	M	W																
8 L3:	ld	f8,2(r2)	F	D	X	M	W																
9	sub	f6,4,8	F	D	X	M	W																
10	addi	f4,f6,10	F	D	X	M	W																
11	store	0(r2),4	F	D	X	M	W																
12 L4:	add	r1,1,4	F	D	X	M	W																
13	add	r2,2,4	F	D	X	M	W																
14	sub	r3,3,1-1	F	D	X*	M	W																
15	blt	r3,0,11	F	D	X	M	W																

CPI = 21/11 = 1,9



REORDENACIÓN	1	2	3	4	5	6	7	8	9	10	11	12	13	14	15	16	17	18	19	20
1 L1: ld	F	D	X	M*	W															
12 add	F	D	X	M	W															
2 mul	F	D	*	X	r	X	m	M	W											
3 blt	F	D	X	M	W															
4 L2: ld	F	D	X	-	M*	W														
5 sub	F	-	-	D	*X	Xa	M	W												
6 store	F	-	D	*X	M	W														
7 br	F	D	X	M	W															
8 L3: ld	F	D	X	M	W															
9 sub	F	D	X	M	W															
10 addi	F	D	X	M	W															
11 store	F	D	X	M	W															
13 L4: add	F	D	X*	M	W															
14 sub	F	D	X	M	W															
15 blt	F	D	*X	M	W															

CPI = 20/11 = 1,82