

Electrical power engineering fundamentals

Module 1: Basic concepts

Belén García
Electrical Engineering Department

In this module we will revise the main physical variables that are important for circuit analysis and some basic relations between them. Additionally we will introduce the main elements of electric circuits.

1 Electrical circuits

Electrical circuits are models that represent real systems. The representation of real systems by means of circuit models allows us to analyse the behaviour of these systems from the prospective of electromagnetism.

The following diagram represents a bulb connected to a battery. Imagine that we want to know the power consumed by the bulb, which depends on the current flowing through it. We can model the system by means of an electric circuit that represents the bulb as a resistor and the battery as a direct current (DC) voltage source.

Applying some basic rules that will be studied in this course we can calculate the current that flows through the bulb and the power absorbed by it.

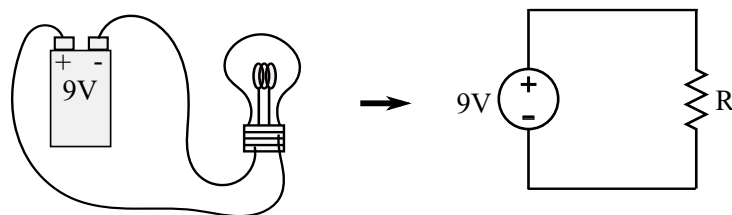

As happens in other fields of the physics and engineering, models are approximated representations of real systems and always dismiss some effects, focusing in the ones that are more relevant for the proposed study. For example, in the previous example we skip the effect of the wires that connect the bulb to the battery.

In this course several simplifications are adopted:

- We consider **lumped-elements circuits**, what means that the effect of each element is concentrated in one point of the space. This implies that currents move

instantaneously throughout the circuit.

- We analyse **circuits in steady state**, assuming that the circuit has been working under the same conditions for enough time to reach this condition. The analysis of transients in power systems is crucial for design and operation purposes and will be studied in further courses. However, transient phenomena in electrical circuits have very short time constants, so steady-state analysis represent the behaviour of real systems in a realistic manner for most of the operation time.

An electrical circuit can be regarded as a system in which an electric excitation is applied and a response is obtained. We will learn some basic rules that will allow us to determine the circuit response as a function of the excitation. Those laws are based in the principles of electromagnetism but include mainly linear relationships, what simplifies the analysis.

2 Main variables for circuit analysis

2.1 Electric charge

Electric charge is a property of the materials that constitutes the origin of electrostatic interaction. There are two types of electric charges: positive and negative charges. The interaction between charges is different depending on their sign. Charges of the same sign repel, while charges of opposite sign attract.

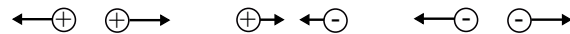

The elementary electric charge is the charge of the electron, but in the International System of Units (SI) charge is measured in Coulombs [C].

$$q_{e^-} = -1.6 \cdot 10^{-19} C$$

2.2 Voltage

The presence of electric charge in a certain region of the space gives rise to a distribution of electric field. As happens with masses in gravitational fields, charges located at any point of the space affected by an electric field have a certain **electric potential energy** which is what we call the potential or **voltage** at this point.

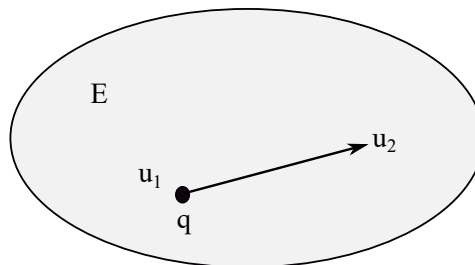

The movement of an electric charge within an electric field involves a change on its electric potential energy. We define the **voltage difference** between two points of the space as the work that must be supplied to move an electric charge between these two points.

$$u = \frac{dw}{dq} \quad (1)$$

Voltage is measured in volts [V] in the SI.

The concept of voltage difference can be understood thinking of a gravitational simile. To move a mass from a point of lower potential energy to another with higher potential energy we must supply work to it. On the other hand, when the mass moves from a higher potential to a lower one it will deliver work. The same thing happens with voltage and charges' movement.

In circuit analysis it is sometimes interesting to mark which terminal of an element is at higher voltage and which is at lower voltage. This is called the **polarity** of the element. Generally the point with higher voltage is marked with a + sign and the point with lower voltage with a - sign. An arrow can also be used to mark the terminals: in electrical circuit analysis the tail of the arrow is placed at the point of higher voltage and the head at the point of lower potential. These notes use the notation +/-.

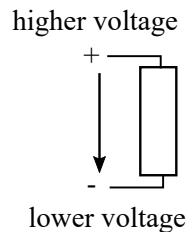

2.3 Current

An important property of a conductive materials is that free electrons can move inside them when they are subjected to a certain voltage difference.

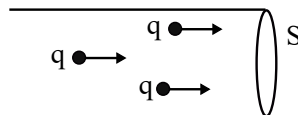

Electric **current** or intensity is defined as the total amount of electric charge that flows through the section of a conductive material per unit of time. The direction of current flow is marked with an arrow.

$$i(t) = \frac{dq}{dt} \quad (2)$$

Current is measured in Amperes [A] in the SI.

There are two different sign criteria that can be adopted when defining electric current:

- **Electronic current criteria.** Current is a movement of electrons (i.e. negative charges) which are the ones that move freely inside conductive materials. If a voltage difference is applied between two sides of a conductive materials, electrons will move from the negative side towards the positive side. This is what happens in real systems.

- **Conventional current criteria.** In circuit analysis it is very common to consider that the positive charges are the ones that move from the positive side of the conductor to the negative side. Note considering a movement of electrons in one direction of the conductor is equivalent to considering a movement of the same amount of positive charge in the opposite direction. Conventional current criteria is adopted throughout this course.

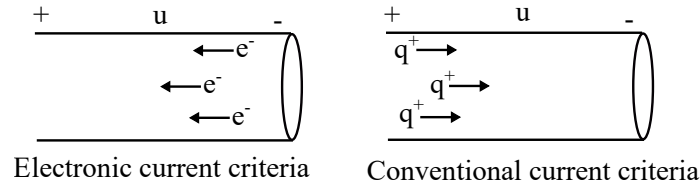

2.4 Electric power

In many problems we need to obtain the amount of power supplied or delivered by an element of a circuit.

By definition **power** is work done per unit of time:

$$p = \frac{dw}{dt} \quad (3)$$

Considering the expressions that were introduced before for voltage (eq. 1) and current (eq. 2) we find an expression that is valid to calculate the electric power absorbed or delivered by a circuit element as a function of the current flowing through it and the voltage drop across it:

$$p = \frac{dw}{dt} = \frac{u \cdot dq}{dt} = u \cdot i \quad (4)$$

In some cases, the circuit elements deliver electric energy and in other cases they absorb energy. If we look at the following diagram, we see that the current (i.e. the electric charges) in the diagram at the left move from a point of higher voltage (u_A) towards a point at lower voltage (u_B). Then, the charges loose energy when going through this element and we can state that the element **absorbs power**. On the other hand, on the circuit at the right, the current flows from a point at lower voltage towards a point with higher voltage. Then, the charges gain energy on their way through the element. This means that the element **delivers power**.

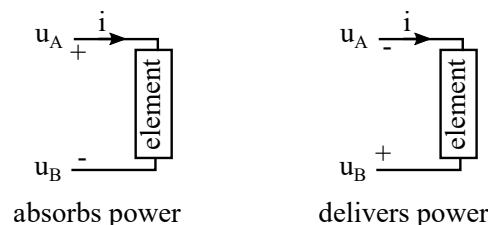

Sign criteria

As will be studied, there are two types of elements in electrical circuits: active elements (i.e. voltage or current sources) which deliver energy to circuits, and passive elements (i.e.

resistors, capacitors and inductors) which absorb energy. For the moment we will focus in sources and resistors for the definition of the sign criteria. In electrical circuits there is always a power balance between the power delivered by sources and the power absorbed by resistors.

The sign criteria for power adopted in this course is:

- Power delivered by sources is taken as positive. In certain cases sources might absorb power; power absorbed by sources is negative.
- Power absorbed by resistors is taken as positive

There is always a balance between power delivered by sources and power absorbed by resistors. According to the adopted sign criteria the **power balance** is:

$$p_{sources} = p_{resistors} \quad (5)$$

3 Kirchhoff's laws

Kirchhoff's laws are a key tool for circuit analysis. These laws were established by Gustav Kirchhoff in 1848 and provide algebraic relationships between the currents and voltages of a circuit.

3.1 Kirchhoff's current law

Kirchhoff's current law (KCL), also referred to as first Kirchhoff's law, is based in the charge conservation principle and states that **the algebraic sum of the currents at any node of the circuit equals zero**.

$$\sum i = 0 \quad (6)$$

A node is a junction of two or more elements of a circuit.

KCL can be illustrated with a hydraulic analogy. In a junction of several pipes that carry a certain flow of water, the total amount of water that enters the junction equals the amount of water that flows out of the junction.

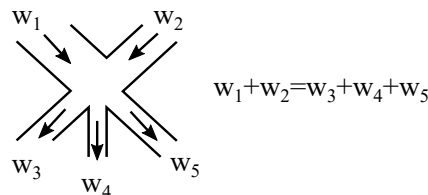

In the same way, as electric charge can not be stored in any point of a circuit, the amount of current that flows into any circuit node equals the amount of charge that flows out of the node.

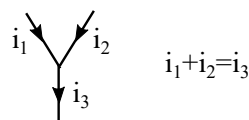

In this course we will assign a positive sign to the currents that flow out of the node and a negative sign to the currents that flow into the node to write KCL ¹. Then in the previous case the obtained equation is:

$$\sum i = 0 \Rightarrow -i_1 - i_2 + i_3 = 0$$

Example

Given the following circuit, calculate the value of i_R :

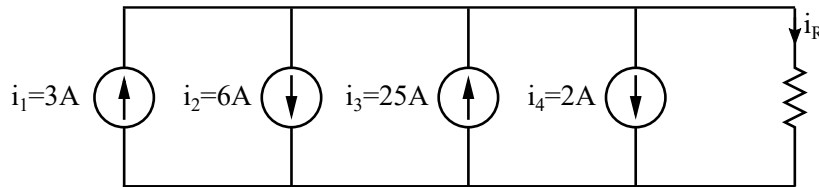

Applying KCL:

$$\sum i = 0 \Rightarrow -i_1 + i_2 - i_3 + i_4 + i_R = 0$$

$$i_R = 3 - 6 + 25 - 2 = 20A$$

3.2 Kirchhoff's voltage law

Kirchhoff's voltage law (KVL), also referred to as second Kirchhoff's law, is based in the energy conservation principle and states that **the algebraic sum of the voltages around a closed path in a circuit equals zero.**

$$\sum u = 0 \tag{7}$$

KVL can be illustrated with a mechanical simile, remember that the voltage level at one point of a circuit is the electrostatic potential energy at this point.

The next figure represents a roller-coaster in which the speed of the trolley is the same at the beginning and at the end of the path.

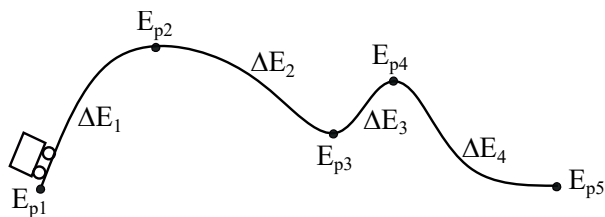

¹The adoption of the sign criteria is arbitrary. If we consider the opposite criteria we would get the same equation (the whole equation is multiplied by -1)

At each point of the path the trolley has a certain potential energy $E_{pk} = m \cdot g \cdot h_k$, and as the trolley moves between two points it losses or gain potential energy:

$$\Delta E_1 = E_{p2} - E_{p1}, \Delta E_2 = E_{p3} - E_{p2}, \Delta E_3 = E_{p4} - E_{p3}, \Delta E_4 = E_{p5} - E_{p4}$$

According to the energy conservation principle, the potential energy rises at growing sections equals the energy drops at decreasing sections.

$$\Delta E_1 + \Delta E_3 = \Delta E_2 + \Delta E_4$$

In the same way, when an electric charge (i.e. a current) moves around a closed path in a circuit, it loses electrostatic potential energy at some sections of the path and gain it at some others being the total gain zero.

The following diagram shows a circuit with four elements which have a certain voltage drop across them. Charges flowing around the loop gain and lose energy on their way, but the voltage drops equal the voltage rises.

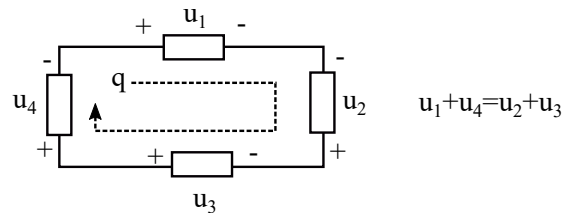

Assigning positive sign to voltage drops and negative sign to voltage rises the equation results ²:

$$\sum u = 0 \Rightarrow u_1 - u_2 - u_3 + u_4 = 0$$

Example

Given the following circuit, calculate the value of u_5 :

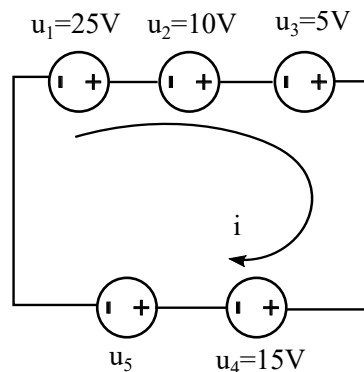

Applying KVL:

²As for the currents the adoption of the sign criteria for the voltage drops and rises is arbitrary.

$$\sum u = 0 \Rightarrow -u_1 - u_2 - u_3 + u_4 + u_5 = 0$$

$$u_5 = 25 + 10 + 5 - 15 = 25V$$

4 Elements of electrical circuits

Electrical circuits consist of a sets of elements interconnected in a way that allows the flow of current and the exchange of electric energy between them.

We can distinguish between two types of circuit elements:

- **Active elements:** Are elements that can supply energy to the circuit ³. Batteries or electric generators are some examples of active elements.

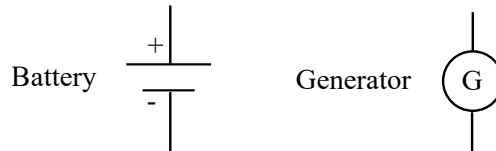

- **Passive elements:** Are elements that absorb or store electric energy. The passive elements that are found in real life (i.e. electric motors, bulbs, heaters...) can be modelled by means of three types of elements: resistors, inductors and capacitors.

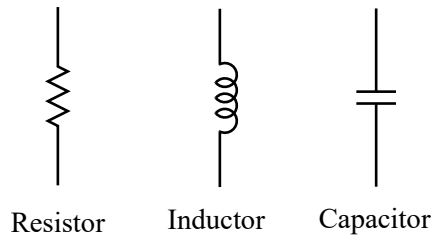

4.1 Resistors

4.1.1 Definition

Resistors are used to model elements that transform electric energy into heat. Some examples of real-life-elements that behave as resistors are bulbs, ovens or electric radiators. For circuit analysis we will characterize these elements by means of the so called **electrical resistance** (R). Electric resistance is measured in Ohms [Ω] in the SI.

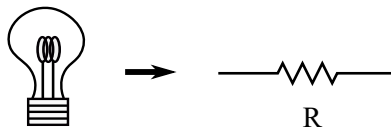

From the physical point of view, electrical resistance quantifies the loss of energy experienced by the electric charges when they flow through a certain path within a conductive

³We will study that under certain circuit configurations active elements might absorb energy

material. The charges collide and those collisions dissipate energy which is transformed into heat.

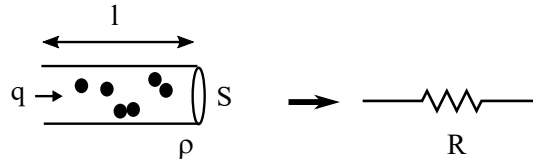

The electrical resistance of an element depends on the nature of the material it is constituted of and on its geometry. The resistivity (ρ) of a material is a physical property that is related with how easily electrons move inside it. Resistivity is the inverse of conductivity (σ) and is measured in $[\Omega] \cdot [m]^{-1}$.

The resistance of an element depends on the resistivity of the material, the length of the current path and the section of the path. This is understandable if we think that a longer path increases the probability of collision, and thus the number of collisions, and that an increase of the section diminishes the collision probability.

$$R = \frac{\rho \cdot l}{S} \quad (8)$$

Additionally we define the conductance (G) of an element as the inverse of its resistance. Conductance is measured in Siemens $[S]$ in the SI.

$$G = \frac{1}{R} \quad (9)$$

4.1.2 Ohm's law

As current flows through a resistor the electric charges always lose energy. The energy of the charges at the entrance of the resistor is higher than the energy when they exit. In circuit analysis this energy loss is characterized as a voltage drop. The voltage drop depends on the amount of charge that flows through the resistor and on its electrical resistance.

The relative polarity between voltage and current in a resistor is **always** as shown in the following diagram. The current enters at the terminal with higher voltage level (+) and exits at the terminal with lower voltage level (-). This is consistent with the principle that a resistor always absorbs electric energy.

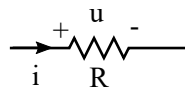

Ohm's law establishes that the relation between the voltage drop and the current flowing through a resistor follows a linear relation:

$$u = R \cdot i \quad (10)$$

The u/i curve in a resistor is always a linear function of slope G :

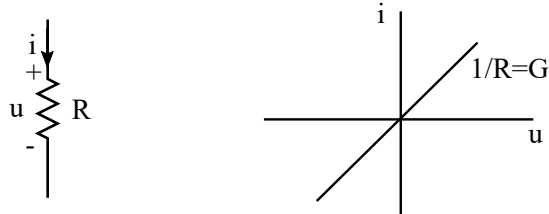

4.1.3 Power absorbed by a resistor

A resistor always absorbs electrical energy. The amount of power absorbed by a resistor can be calculated as the product of the voltage drop across the resistor and the current flowing through it. Additionally, alternative equations can be derived that are useful to calculate power in many cases:

$$p_R = u \cdot i = R \cdot i^2 = \frac{u^2}{R} \tag{11}$$

4.2 Ideal sources

Sources are elements that supply energy to electrical circuits.

Ideal sources are elements that do not exist in real life but that, in many cases, are good models to represent real active elements. We can differentiate between two types of ideal sources: ideal voltage sources and ideal current sources.

4.2.1 Ideal voltage sources

An ideal voltage source is an element that keeps a constant voltage drop across its terminals regardless the current flowing through it. Voltage sources can provide direct current (DC) voltage or alternating current (AC) voltage. The following diagram shows the symbol for both types of ideal voltage sources:

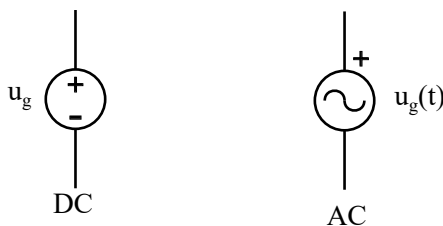

The u/i curve of a DC voltage source shows that the voltage drop across it is constant for currents:

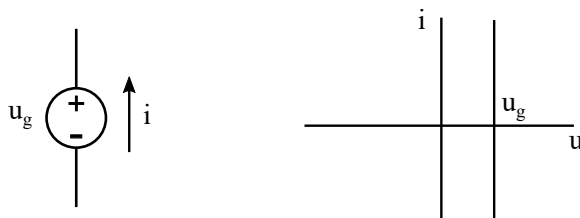

As will be studied later in this course, the voltage drop across an AC voltage source varies in time following a sinusoidal function with constant amplitude and root mean square value for any current flowing through it.

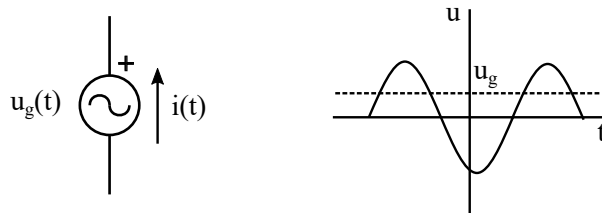

To characterize an ideal DC voltage source we need to know its **output voltage**, which is the voltage drop across its terminals, and its **polarity**. The polarity of the source informs us about which terminal is at a higher voltage level (the one denoted with a sign +) and which one is at lower voltage level (the one denoted with a sign -).

The power supplied by a voltage source can be calculated as the product of the output voltage and the current flowing through it.

$$p_g = u_g \cdot i \tag{12}$$

Although voltage sources are active elements, under some configurations they might absorb power. To determine if a source absorbing or generating power we must look at the relative polarity of voltage and current. A source delivers power if the current flows from + to -. On the contrary, a source delivers power if the current flows from - to +.

In the following example, the source on the left delivers power and the source on the right absorbs power. According to the sign criteria established in section 2.4 we will take delivered power as positive and absorbed power as negative.

Example

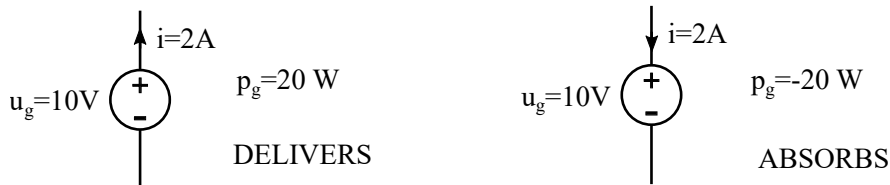

4.2.2 Ideal current sources

An ideal current source is an element that keeps a constant current flow through it regardless the voltage drop across its terminals.

The following diagram shows the symbol for an ideal current source and its u/i curve. As it can be seen the current is constant for any value of the voltage across its terminals.

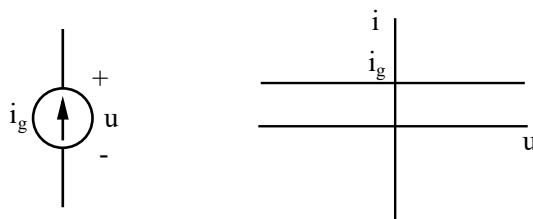

Later in the course we will also study AC ideal current sources, which provide a sinusoidal current with constant amplitude and root mean square value.

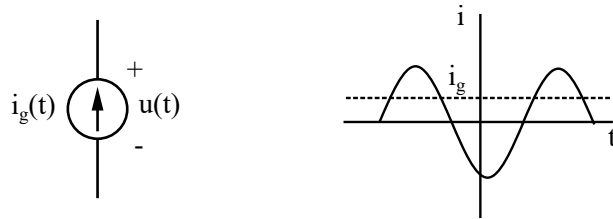

An ideal current source is defined by its **output current**, which is the current flowing through it, and its **polarity**, which is the direction of the current. The polarity of a current source is indicated by the direction of the arrow.

The power supplied by an ideal current source can be calculated as the product of the output voltage and the current flowing through it.

$$p_g = i_g \cdot u \quad (13)$$

As happened with ideal voltage sources, ideal current sources might also absorb power under certain situations. To determine if a source is absorbing or generating power we must look at the relative polarity between voltage and current. A source delivers power if the current flows from + to - and delivers power if the current flows from - to +.

In the example below, the source on the left delivers power and the source on the right absorbs power. As for voltage sources, according to our sign criteria, we take delivered power as positive and absorbed power as negative.

Example

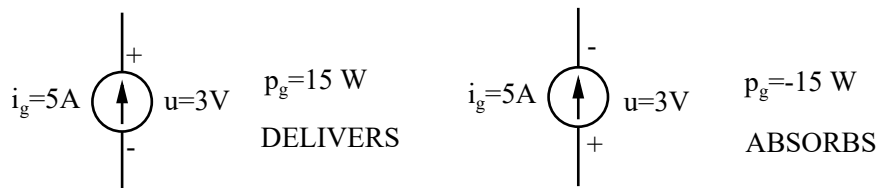

4.3 Real sources

The sources that have been studied so far are idealizations of real elements. Real sources always have internal losses and voltage drops which are modelled by means of internal resistors.

4.3.1 Real voltage sources

A DC real voltage source can be modelled as a voltage source in series with a resistor. The resistor represents the resistance of the source internal elements, such as wires or connectors. Ideally, the value of the resistance is very small in real devices.

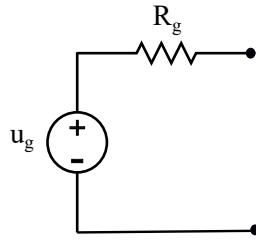

When a real voltage source supplies energy to a resistor, the supplied voltage (u) is not constant but depends on the current (i) flowing through the circuit:

$$u = u_g - R_g \cdot i \quad (14)$$

where

$$i = \frac{u_g}{R_g + R} \quad (15)$$

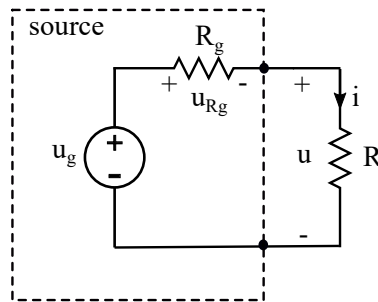

The following diagram shows the u/i curve for a real voltage source. As was explained before the output voltage is not constant but depends on the current supplied by the source. If the current is zero, the internal voltage drop across the resistor (u_{R_g}) is also zero. That is the case when the circuit is open (i.e. $R = \infty$). On the other hand, if a short circuit is connected between the two terminals of the real voltage source, the current supplied is maximum and the voltage drop at the internal resistance equals u_g .

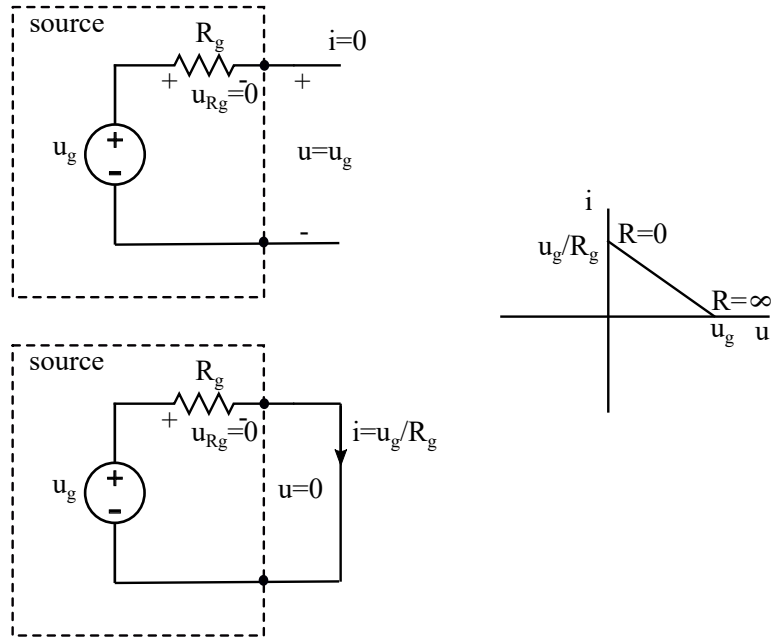

The power supplied by a real voltage source to a resistor connected between its terminals is:

$$p_g = R \cdot i^2 = R \cdot \frac{u_g^2}{(R_g + R)^2} \quad (16)$$

and the internal losses of the source:

$$p_{R_g} = u_{R_g} \cdot i = R_g \cdot \frac{u_g^2}{(R_g + R)^2} \quad (17)$$

The, the efficiency of the real source depends on the resistance connected to it:

$$\eta = \frac{p_g}{p_g + p_{R_g}} = \frac{R}{R_g + R} \quad (18)$$

4.3.2 Real current sources

DC real current sources can be modelled as an ideal current source in parallel with a resistor.

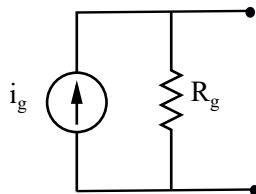

When a real current source supplies energy to a resistor, the supplied current (i) is not constant but depends on the voltage (u) across its terminals.

$$i = i_g - \frac{u}{R_g} \quad (19)$$

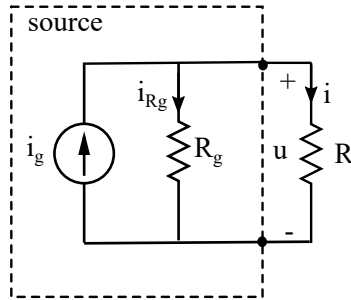

As for real voltage sources, the efficiency of a real current source depends on the relation between the internal resistance of the source and the resistor connected to it:

$$\eta = \frac{p_g}{p_g + p_R} = \frac{R_g}{R_g + R} \quad (20)$$

5 Association of elements in electric circuits and other equivalences

In some cases we need to solve circuits with a relatively high number of passive or active elements, what complicates the calculation of the voltages and the currents on them. For certain configurations these elements can be associated or redrawn obtaining simpler equivalent circuits in which the calculation of voltages or currents is more simple. In this section we will study some of circuit transformations.

5.1 Association of resistors

5.1.1 Series connected resistors

We say that two or more elements are connected in **series** if the **same current** flows through them. The n resistors in the figure are in series, since the current i entering the net has no other path to follow and the current is the same for all the resistors.

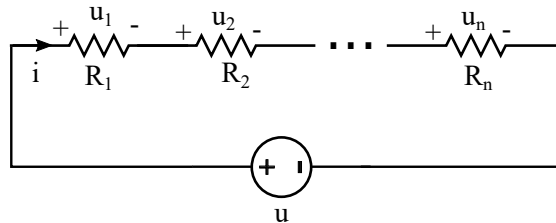

Each resistor has a voltage drop that is given by Ohm's law:

$$\begin{aligned} u_1 &= R_1 \cdot i \\ u_2 &= R_2 \cdot i \\ &\dots \end{aligned}$$

$$u_n = R_n \cdot i$$

The total voltage u can be calculated using KVL:

$$u = u_1 + u_2 + \dots + u_n = R_1 \cdot i + R_2 \cdot i + \dots + R_n \cdot i = (R_1 + R_2 + \dots + R_n) \cdot i$$

The set of n resistors can be redrawn as an equivalent resistance R_{eq} :

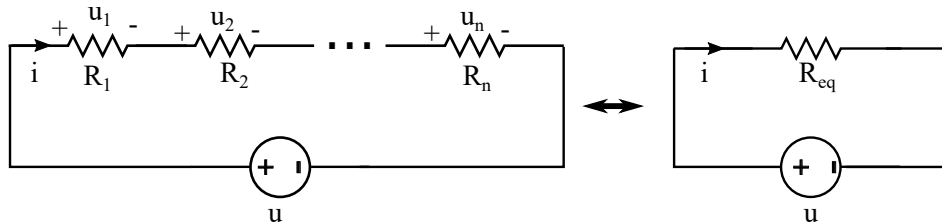

$$R_{eq} = R_1 + R_2 + \dots + R_n = \sum_k R_k \quad (21)$$

$$u = R_{eq} \cdot i$$

Seen from the voltage source the effect of the resistors connected in series is identical to the effect of the equivalent resistance and it would not be possible to distinguish both configurations. We say that both configurations are **equivalent**.

Example

Given the following circuit, calculate the current i .

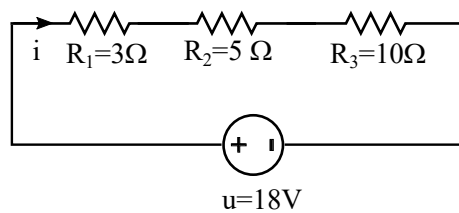

We associate all the resistors in series finding a simplified equivalent circuit

$$R_{eq} = R_1 + R_2 + R_3 = 3 + 5 + 10 = 18\Omega$$

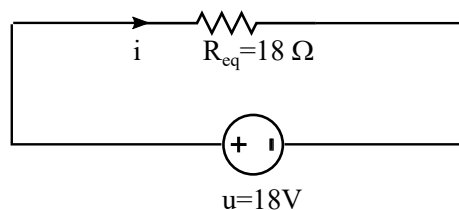

The current can be calculated using Ohm's law:

$$i = \frac{u}{R_{eq}} = 1A$$

If we want to calculate the voltage drop across the original resistors R_1 , R_2 and R_3 , we go back to the original circuit and use the obtained current to calculate them.

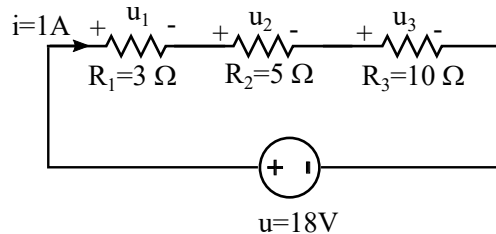

$$u_1 = R_1 \cdot i = 3V \quad u_2 = R_2 \cdot i = 5V \quad u_3 = R_3 \cdot i = 10V$$

The voltage divider equation

Some electronic devices use nets formed by several resistors to obtain a fraction of the voltage of a source. Those devices are based on the fact that the voltage drop across each of the series-connected resistors is a portion of the voltage of the source.

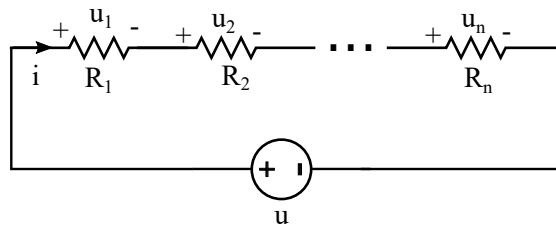

The voltage drop at resistor k is:

$$u_k = R_k \cdot i$$

As the current is:

$$i = \frac{u}{R_1 + R_2 + \dots + R_n}$$

The equation to calculate the voltage drop across resistor k is:

$$u_k = \frac{R_k}{R_{eq}} \cdot u \quad (22)$$

The voltage-divider equation is also useful for circuit analysis purposes when we want to calculate the voltage drop across one of the resistors in a series-connected set of resistors.

5.1.2 Parallel connected resistors

Two or more elements are connected in **parallel** if they have the **same voltage across them**. The n resistors in the figure are in parallel since the voltage u across all of them is the same.

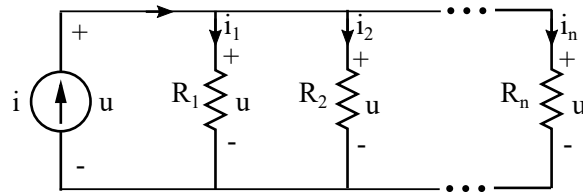

Each resistor has a different current:

$$i_1 = \frac{u}{R_1} = u \cdot G_1$$

$$i_2 = \frac{u}{R_2} = u \cdot G_2$$

$$i_n = \frac{u}{R_n} = u \cdot G_n$$

The total current i can be calculated using KCL:

$$i = i_1 + i_2 + \dots + i_n = \frac{u}{R_1} + \frac{u}{R_2} + \dots + \frac{u}{R_n} = u \cdot \left(\frac{1}{R_1} + \frac{1}{R_2} + \dots + \frac{1}{R_n} \right)$$

The set of n resistors can be redrawn as an equivalent resistance R_{eq} :

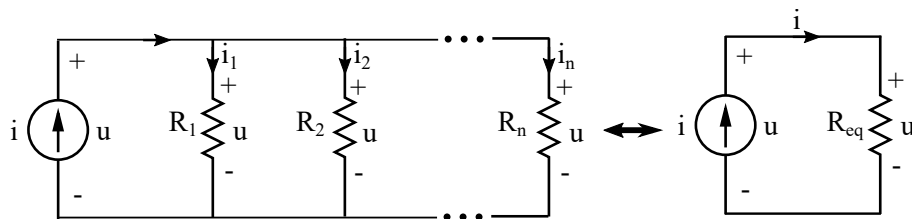

$$\frac{1}{R_{eq}} = \frac{1}{R_1} + \frac{1}{R_2} + \dots + \frac{1}{R_n} = \sum_k \frac{1}{R_k} \quad (23)$$

$$i = \frac{u}{R_{eq}}$$

The equations can also be expressed in terms of conductance:

$$G_{eq} = \sum_i G_i \quad i = u \cdot G_{eq} \quad (24)$$

Seen from the current source, the effect of the n resistors connected in parallel is identical to the effect of the equivalent resistance; it would not be possible to distinguish both configurations. We say that both configurations are **equivalent**.

The current divider equation

A current divider consists of a circuit constituted by several parallel connected resistors that can be used to obtain a fraction of the output current of a source

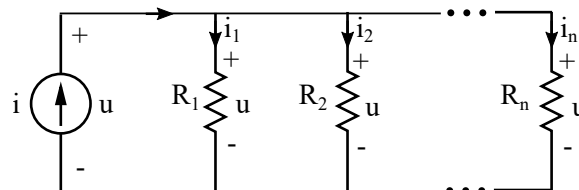

The current at the resistor k is

$$i_k = \frac{u}{R_k} = u \cdot G_k$$

As the voltage is:

$$u = \frac{i}{G_1 + G_2 + \dots + G_n}$$

The equation to calculate the current flowing through resistor k is:

$$i_k = \frac{G_k}{G_{eq}} \cdot i \quad (25)$$

The current-divider equation is also useful for circuit analysis purposes when we want to calculate the current flowing through one of the resistors in a parallel-connected set of resistors.

In the particular case of two resistors connected in parallel (which we will find very often when analysing electric circuits):

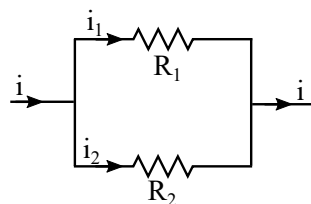

the expressions for the currents i_1 and i_2 are:

$$i_1 = \frac{R_2}{R_1 + R_2} \cdot i \quad i_2 = \frac{R_1}{R_1 + R_2} \cdot i \quad (26)$$

5.2 Association of ideal sources

5.2.1 Association of ideal voltage sources in series

Several ideal voltage sources connected in series can be associated to find an equivalent voltage source.

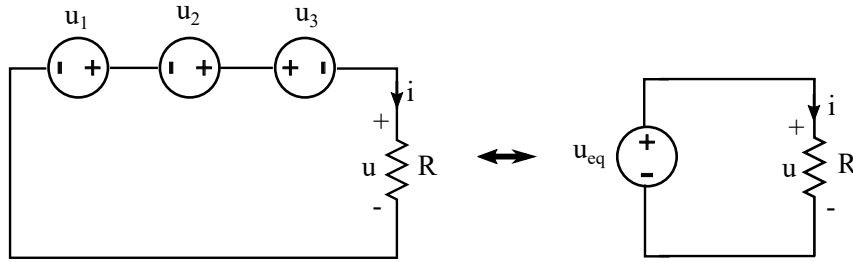

The output voltage of the equivalent voltage source is obtained as the sum of the voltages of the individual sources taking into account their polarity:

$$u_{eq} = u_1 + u_2 - u_3 \quad (27)$$

Seen from the resistor R both configurations are **equivalent**, what means that the current flow and the voltage drop across the resistor are identical in both cases.

Two or more ideal current sources with different output current can never be connected in series, as two elements are series-connected when the current flowing through them is the same.

5.2.2 Association of ideal current sources in parallel

Several ideal current sources connected in parallel can be associated to find an equivalent ideal current source:

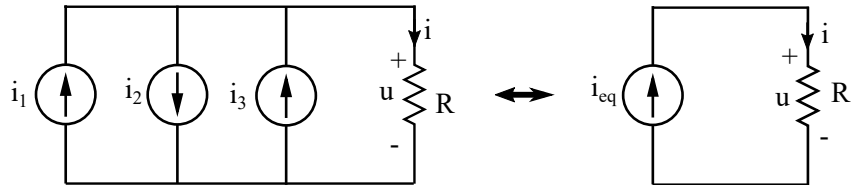

The output current of the equivalent ideal current source is obtained as the algebraic sum of the output currents of the ideal current sources:

$$i_{eq} = i_1 - i_2 + i_3 \quad (28)$$

For resistor R both configurations are **equivalent**, what means that the current flow and the voltage drop across it are identical in both cases.

Ideal voltage sources of different output voltages can never be parallel-connected, as that would require that the voltage drops across them were the same.

5.3 Transformation of real sources

There is another equivalence that is sometimes useful for circuit analysis which is the transformation of real voltage sources into real current sources and the other way around.

A real voltage source and a real current source are equivalent if the current (i) and the voltage (u) supplied to an element connected between the terminals of both sources is the same.

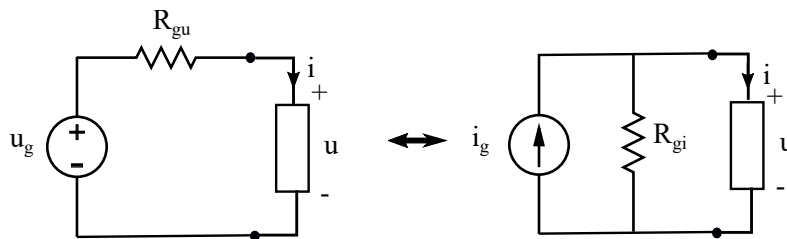

If we analyze the circuit fed by the voltage source the voltage u would be:

$$u = u_g - R_{gu} \cdot i$$

In the circuit with the current source current i would be:

$$i = i_g - \frac{u}{R_{gi}}$$

Then, we can derive that both sources are equivalent if these two conditions are true:

$$i_g = \frac{u_g}{R_{gu}} \quad R_{gu} = R_{gi} \quad (29)$$

Example

Find the ideal current source which is equivalent to an ideal voltage source with internal resistance $R_g = 3\Omega$ and output voltage $u_g = 30V$.

The current source would have internal resistance 3Ω and an output current:

$$i_g = \frac{u_g}{R_g} = \frac{30}{3} = 10A$$

6 Additional passive elements: inductors and capacitors

Inductors and capacitors are passive elements that take energy from sources and store it into electromagnetic fields. These elements are particularly important for AC circuits.

6.1 Capacitors

6.1.1 Working principle

A capacitor is an element that stores electric energy in an electric field. Capacitors are constituted by two metallic plates separated a certain distance with a dielectric material placed between them, which impedes the flow of charge between the two plates.

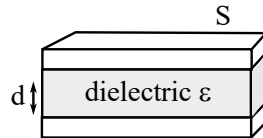

If a voltage difference is applied between the two plates, a charge displacement takes place so that one of the plates becomes charged with positive charge and the other one with negative charge. An electric field is established between the plates and a polarization process takes place in the dielectric material in which electric dipoles become orientated in the direction of the field.

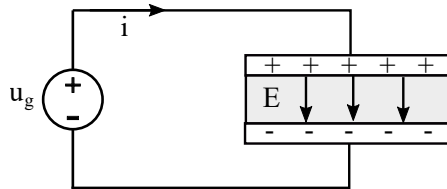

The amount of charge displaced in the capacitor is proportional to the voltage drop across it, and the proportionality factor is called the **capacitance** of the capacitor (C). Capacitance is measured in Farads [F] in the SI.

$$q = C \cdot u \quad (30)$$

The capacitance depends either on the geometry of the capacitor and on the properties of the dielectric material that is placed between the metallic plates:

$$C = \frac{\varepsilon \cdot S}{d} \quad (31)$$

where d is the distance between the plates, S is the surface of the plates and ε is the permittivity of the dielectric material.

The permittivity of a material is related related with its response to the effect of an electric field, in terms of polarization, and it is calculated as the product of the relative permittivity of the dielectric material (ε_r) and the permittivity of the vacuum (ε_0):

$$\varepsilon = \varepsilon_0 \cdot \varepsilon_r \quad (32)$$

In electric circuits, capacitors are represented with the following symbol:

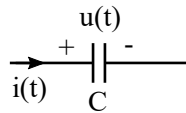

As was explained before, the application of a voltage drop across the plates of a capacitor gives rise to a charge movement that implies the establishment of a current. To obtain the relation between the voltage and the current in a capacitor, we should apply derivatives to the equation that relates charge and voltage:

$$q = C \cdot u \Rightarrow \frac{dq}{dt} = C \cdot \frac{du}{dt} \quad (33)$$

$$i(t) = C \cdot \frac{du(t)}{dt} \quad (34)$$

We can also calculate the voltage drop across the terminals of the capacitor for a certain current:

$$u(t) = u(t_0) + \frac{1}{C} \int_{t_0}^t i(t) dt \quad (35)$$

As can be seen, the voltage drop across a capacitor in the instant t depends on the voltage at a previous instant t_0 . This means that the voltage across a capacitor always varies smoothly. We say that voltage across a capacitor is a state variable.

6.1.2 Capacitors in DC circuits

If we apply a DC voltage drop to a capacitor, for example using a voltage source of constant output voltage u_g , the current flowing through the capacitor would be zero:

$$i(t) = C \cdot \frac{du(t)}{dt} = C \cdot \frac{du_g}{dt} = 0 \quad (36)$$

This means that **in DC**, in steady state, **a capacitor behaves as an open circuit**.

In transient conditions, for example after the connection or disconnection of a source, the voltage will change and the current will be different from zero.

If we look at the following example:

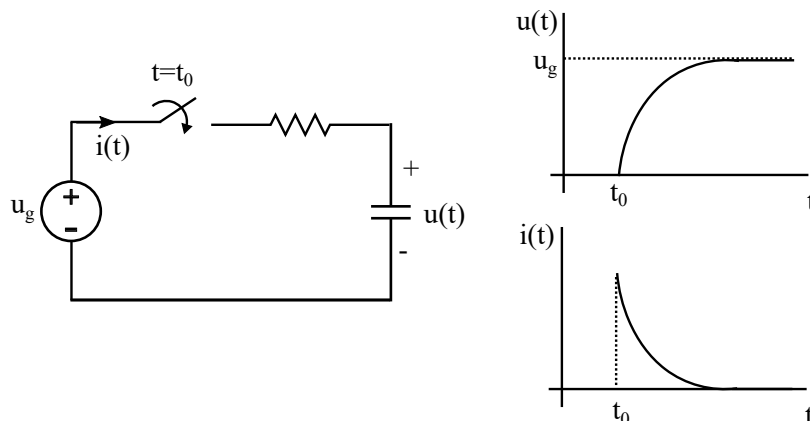

Immediately after the connection of the source, the voltage across the capacitor, which was zero, begins to rise until it reaches the steady state condition in which $u = u_g$. During the transient, there is a current that carries the energy from the source to the capacitor. This process is called **capacitor charging**.

Once the capacitor is charged the current becomes zero and the voltage across the capacitor remains equal to u_g until a discharge process takes place.

6.1.3 Power and energy

The power absorbed by a capacitor can be calculated with the general expression for the electric power:

$$p = u \cdot i = u \cdot C \cdot \frac{du}{dt} \quad (37)$$

Thus, the energy stored in a capacitor is:

$$p = \frac{dw}{dt} \Rightarrow \int dw = C \int u \cdot du \quad (38)$$

$$w = \frac{1}{2} \cdot C \cdot u^2 \quad (39)$$

6.1.4 Association of capacitors

As for resistors and sources we will also be able to find equivalent capacitances to represent sets of capacitors that are connected in series or parallel.

n capacitors series-connected (i.e. with the same current flowing through them), can be replaced by an equivalent capacitance, as shown in the figure:

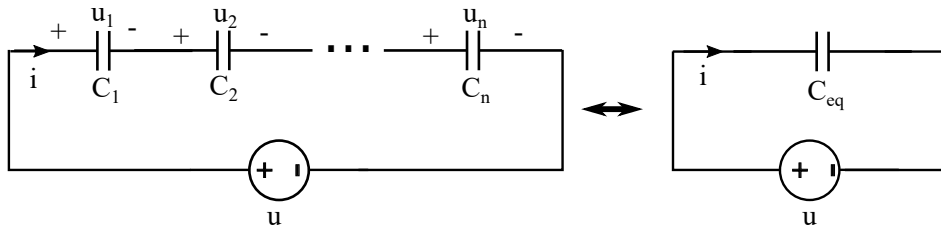

To obtain an expression for C_{eq} KVL is applied and derivatives are taken in the resulting equation:

$$u = u_1 + u_2 + \dots + u_n \quad (40)$$

$$\frac{du}{dt} = \frac{du_1}{dt} + \frac{du_2}{dt} + \dots + \frac{du_n}{dt} = \left(\frac{1}{C_1} + \frac{1}{C_2} + \dots + \frac{1}{C_n} \right) \cdot i = \frac{1}{C_{eq}} \cdot i \quad (41)$$

The equivalent capacitance is:

$$\frac{1}{C_{eq}} = \frac{1}{C_1} + \frac{1}{C_2} + \dots + \frac{1}{C_n} = \sum_k \frac{1}{C_k} \quad (42)$$

Likewise, a set of n capacitors parallel-connected can be replaced by an equivalent capacitance:

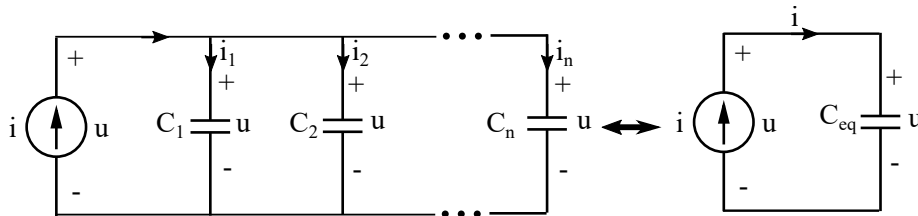

To find an expression for C_{eq} KCL is applied to the original net:

$$i = i_1 + i_2 + \dots + i_n = (C_1 + C_2 + \dots + C_n) \cdot \frac{du(t)}{dt} = C_{eq} \cdot \frac{du(t)}{dt} \quad (43)$$

finding that:

$$C_{eq} = C_1 + C_2 + \dots + C_n = \sum_k C_k \quad (44)$$

6.2 Inductors

6.2.1 Working principle

Inductors are passive elements that take energy from a source and store it in a magnetic field.

Inductors are constituted by a wire wrapped around a core, generally made of a magnetic material, forming N turns:

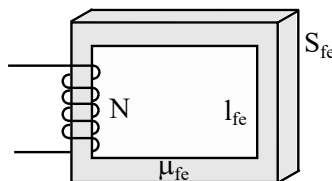

When current circulates through the wire a magnetic flux is created according to Ampere's law:

$$N \cdot \phi = L \cdot i \quad (45)$$

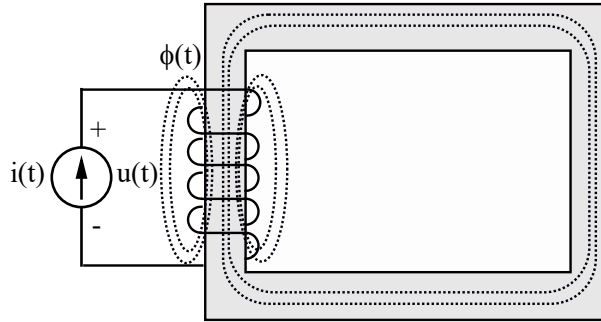

The parameter that defines the relation between the applied current and the flux is the **self inductance** or inductance (L). The inductance of an inductor depends on the number of turns, the section of the magnetic path (S_{fe}), the average length of the magnetic path (l_{fe}) and the permeability of the magnetic material (μ_{fe})

$$L = \frac{N^2 \cdot S_{fe} \cdot \mu_{fe}}{l_{fe}} \quad (46)$$

The inductance is measured in Henry [H] in the SI.

Inductors are represented by the following symbol in electric circuits:

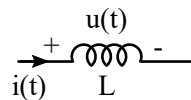

To obtain the relation u/i in an inductor, we should consider that according to Faraday's law the relation between the voltage across the terminals ⁴ of the inductor and the flux are related by:

$$u = N \cdot \frac{d\phi}{dt} \quad (47)$$

And as:

$$N \cdot \phi = L \cdot i \quad \Rightarrow \quad N \cdot \frac{d\phi}{dt} = L \cdot \frac{di}{dt} \quad (48)$$

then:

$$u(t) = L \cdot \frac{di(t)}{dt} \quad (49)$$

We can also calculate the current flowing through the inductor given a certain voltage:

$$i(t) = i(t_0) + \frac{1}{L} \int_{t_0}^t u(t) dt \quad (50)$$

⁴voltage= - electromotive force

As can be seen, the current through an inductor at the instant t depends on the current at a previous instant t_0 . This means that the current through an inductor always varies smoothly. We say that current through an inductor is a state variable.

6.2.2 Inductors in DC circuits

If an inductor is fed with a DC current source of constant value i_g , the voltage across the inductor would be zero:

$$u(t) = L \cdot \frac{di(t)}{dt} = L \cdot \frac{di_g}{dt} = 0 \quad (51)$$

This means that **in DC**, in steady state, **an inductor behaves as a short circuit**.

In transient conditions, for example after the connection or disconnection of the source, the current flowing through the inductor changes; thus the voltage drop across the inductor is different from zero for some instants until the steady state is reached.

6.2.3 Power and energy

The power absorbed by an inductor is:

$$p = u \cdot i = i \cdot L \frac{di}{dt} \quad (52)$$

The energy stored in a inductor is:

$$p = \frac{dw}{dt} = L \cdot i \cdot \frac{di}{dt} \quad (53)$$

$$\int dw = L \int i \cdot di \quad (54)$$

$$w = \frac{1}{2} \cdot L \cdot i^2 \quad (55)$$

6.2.4 Association of inductors

As with other elements, it is possible to represent a set of inductors series or parallel connected by means of an equivalent inductance.

If we have n inductors in series (i.e. with the same current flowing through them):

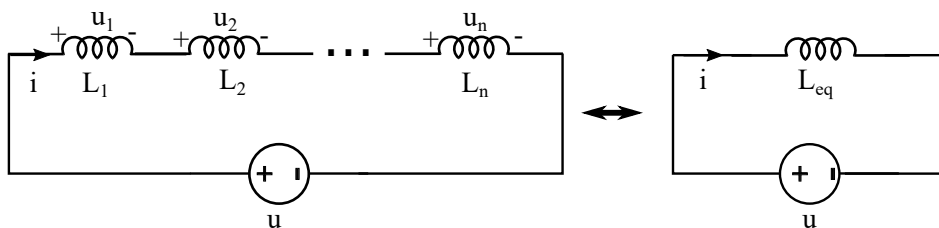

$$u = u_1 + u_2 + \dots + u_n = (L_1 + L_2 + \dots + L_n) \cdot \frac{di}{dt} = L_{eq} \cdot \frac{di}{dt} \quad (56)$$

The series equivalent inductance is:

$$L_{eq} = L_1 + L_2 + \dots + L_n = \sum_i L_i \quad (57)$$

A set of n inductors parallel-connected can also be replaced by an equivalent inductance:

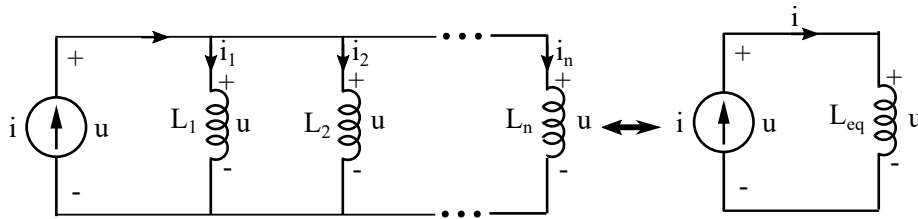

$$i = i_1 + i_2 + \dots + i_n \quad (58)$$

$$\frac{di}{dt} = \frac{di_1}{dt} + \frac{di_2}{dt} + \dots + \frac{di_n}{dt} = \left(\frac{1}{L_1} + \frac{1}{L_2} + \dots + \frac{1}{L_n} \right) \cdot u = \frac{1}{L_{eq}} \cdot u \quad (59)$$

The parallel equivalent inductance is:

$$\frac{1}{L_{eq}} = \frac{1}{L_1} + \frac{1}{L_2} + \dots + \frac{1}{L_n} = \sum_i \frac{1}{L_i} \quad (60)$$

6.3 Coupled inductors

6.3.1 Working principle

Lets consider two inductors that are close to each other, as the ones represented in the figure:

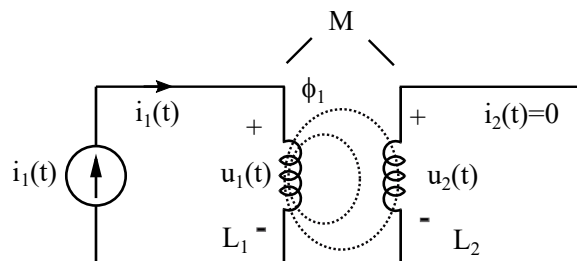

Inductor 1 is fed with a current $i_1(t)$ and inductor 2 the other has no current flowing through it. The circulation of $i_1(t)$ induces a flux ϕ_1 . If some of the field lines link inductor 2, according to Faraday's law, an electromotive force is induced and a voltage drop u_2 appears across the terminals of inductor 2.

The degree of coupling between both inductors is quantified with the **mutual inductance coefficient** (M), which is measured in Henry [H]. M depends on the self inductances L_1 and L_2 and on the coefficient of coupling k :

$$M = k \cdot \sqrt{L_1 \cdot L_2} \quad 0 \leq k \leq 1 \quad (61)$$

In the case of the diagram, the voltages u_1 and u_2 would be:

$$u_1(t) = L_1 \cdot \frac{di_1(t)}{dt} \quad (62)$$

$$u_2(t) = M \cdot \frac{di_1(t)}{dt} \quad (63)$$

If now we supply the inductor 2 with a current i_2 a second flux ϕ_2 will be created:

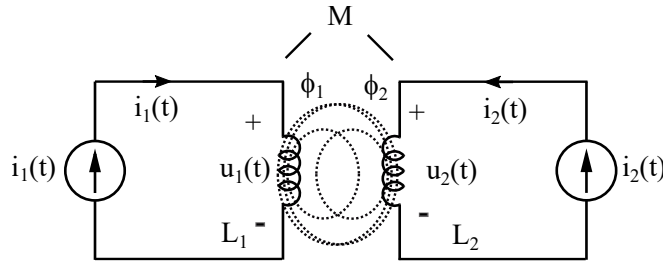

In this case, the voltage drop across each inductor depends on the current flowing through it, but also on the current flowing through the other inductor:

$$u_1(t) = L_1 \cdot \frac{di_1(t)}{dt} + M \cdot \frac{di_2(t)}{dt} \quad (64)$$

$$u_2(t) = L_2 \cdot \frac{di_2(t)}{dt} + M \cdot \frac{di_1(t)}{dt} \quad (65)$$

6.3.2 Polarity of the coupling

For simplicity's sake in the previous examples the mutual inductance terms have been taken as positive in all cases. However, the definition of the polarity of the coupling would require a deeper analysis, which in circuit analysis is normally done considering the **dot convention**.

One terminal at each inductor is labelled with a dot. Then if a current “enters” at the dotted terminal of an inductor, the reference polarity of the voltage induced in the other inductor is positive at its dotted terminal. If a current “leaves” the dotted terminal of an inductor, the reference polarity of the voltage induced in the other inductor is negative at its dotted terminal.

As can be seen in the next three examples, the sign of the mutual inductance term depends on the position of the dotted terminals.

Example 1

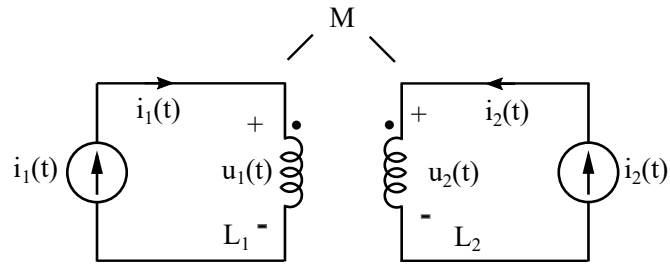

$$u_1(t) = L_1 \cdot \frac{di_1(t)}{dt} + M \cdot \frac{di_2(t)}{dt}$$

$$u_2(t) = L_2 \cdot \frac{di_2(t)}{dt} + M \cdot \frac{di_1(t)}{dt}$$

Example 2

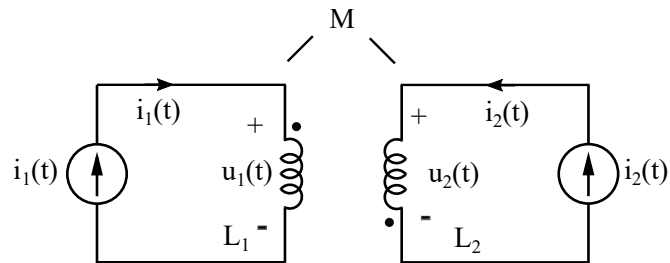

$$u_1(t) = L_1 \cdot \frac{di_1(t)}{dt} - M \cdot \frac{di_2(t)}{dt}$$

$$u_2(t) = L_2 \cdot \frac{di_2(t)}{dt} - M \cdot \frac{di_1(t)}{dt}$$

Example 3

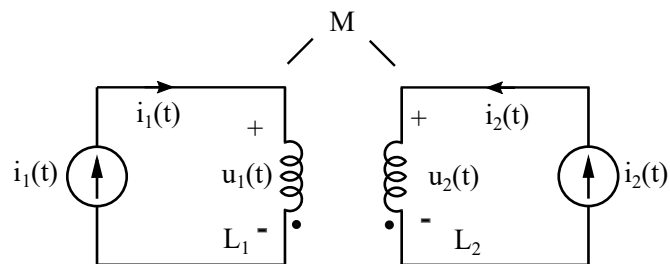

$$u_1(t) = L_1 \cdot \frac{di_1(t)}{dt} + M \cdot \frac{di_2(t)}{dt}$$

$$u_2(t) = L_2 \cdot \frac{di_2(t)}{dt} + M \cdot \frac{di_1(t)}{dt}$$

6.3.3 Applications of coupled inductors: Transformers

Coupled inductors are applied in many elements of real life such as electric motors or protection devices. One of the main applications of coupled inductors are the transformers, which are used to transform the voltage level of electric energy.

Transformers are constituted by two coupled inductors and a magnetic core:

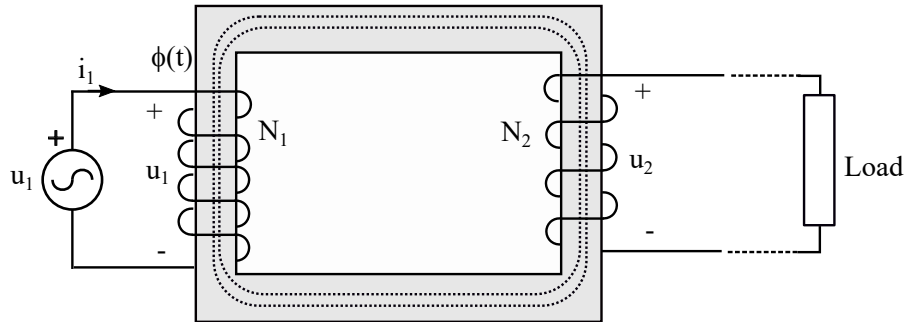

One of the inductors is fed at the primary voltage u_1 ; current i_1 flows inducing a flux within the core. As the flux links inductor 2 it induces a voltage drop u_2 across it. If the number of coils of the two inductors is different, the voltage u_2 differs from u_1 .

The transformation relation of the transformer is defined as:

$$r_t = \frac{N_1}{N_2} = \frac{u_1}{u_2} \quad (66)$$

The use of transformers require that the voltage u_1 is variable. This is one of the main reasons to use alternate current in power systems, as will be explained later in the course.