

## Module 4: Three-phase systems

Belén García  
Electrical Engineering Department

This module introduces the main concepts of balanced three-phase systems, defining the properties of this type of configuration and justifying its application to power systems. We will learn how to analyse the currents and voltages of three-phase systems using the one-phase equivalent approach for wye and delta connected configurations. Finally, some power related concepts applicable to these systems are introduced.

### 1 Configuration of three-phase systems

Power systems transfer big amounts of power from generators to loads. As explained in previous sections, the design of power systems is conceived to minimize the power losses at the lines using to this end power and distribution transformers. Transformers enable the transmission of energy at high voltage levels increasing the efficiency of power systems.

Power systems are commonly constructed with a three-phase configuration, as the one shown in the following figure:

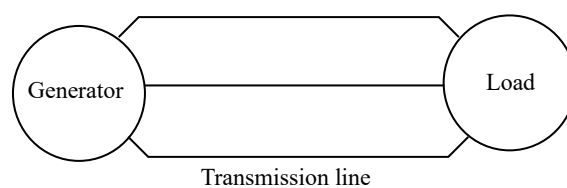

#### 1.1 Three-phase generators

Generators in power plants are generally three-phase as these type of rotating machines are more robust from the mechanical point of view, have a lower cost and require a smaller space to generate the same amount of power.

Three phase generators incorporate three electric circuits that provide a three phase system of voltages, that is: three sinusoidal voltages of the same frequency and the same amplitude

and with relative phase-shift  $120^\circ$ .

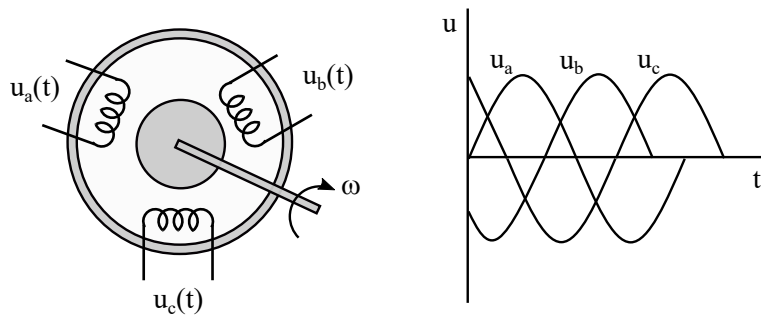

For circuit analysis purposes three-phase generators are commonly represented as three voltage sources connected between them. As will be explained throughout this module the connection between phases can be done in wye or delta. The phases of a generator are **wye connected** if three terminals, one of each phase, share a common point, which is called the **neutral point**, while the other three terminals are connected to the system. Alternatively, a generator is **delta connected**, when each source is connected to the other two sources forming a triangle, as shown in the following diagram:

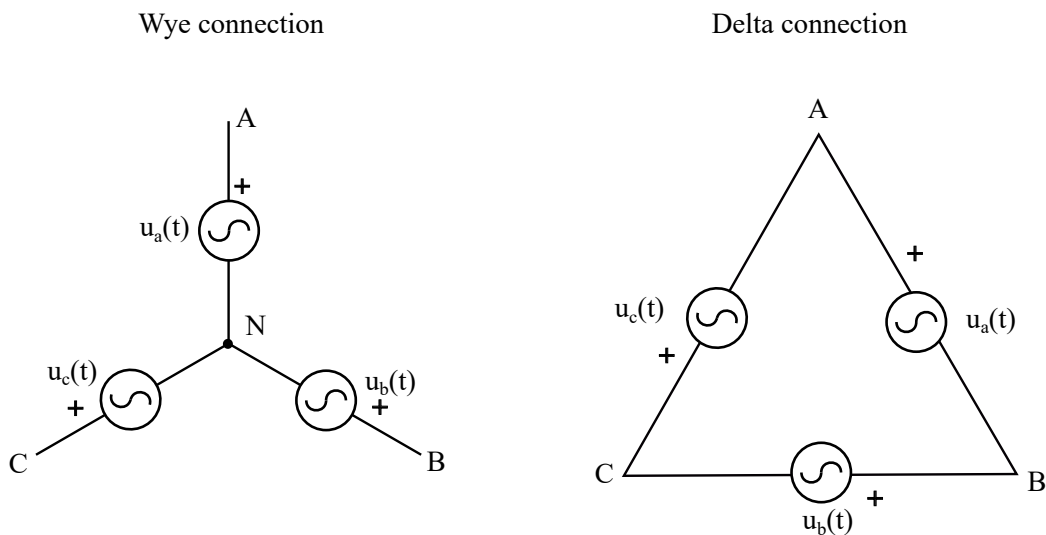

This module is focused towards the analysis of **three-phase balanced systems**, which are those in which the voltages and the currents of the three phases have the same amplitude. A balanced three-phase system of voltages is composed of three sinusoidal voltages of the same amplitude and a relative phase-shift  $120^\circ$ :

$$u_a(t) = \frac{\rho_-}{2} U \cos(\omega t) \quad (1)$$

$$u_b(t) = \frac{\rho_-}{2} U \cos(\omega t - 120^\circ) \quad (2)$$

$$u_c(t) = \frac{\rho}{2} U \cos(\omega t + 120^\circ) \quad (3)$$

The phasors that represent this type of systems are:

$$\underline{U}_a = U \angle 0^\circ \quad (4)$$

$$\underline{U}_b = U \angle -120^\circ \quad (5)$$

$$\underline{U}_c = U \angle 120^\circ \quad (6)$$

If the relative phase shift between the voltages are as in the previous equations ( $u_a$  leading  $u_b$  and lagging  $u_c$ ) we say that the system has **positive sequence**. In some cases, the sequence of the phases changes and the voltage of phase b leads the voltage of phase a; these type of systems have a **negative sequence**.

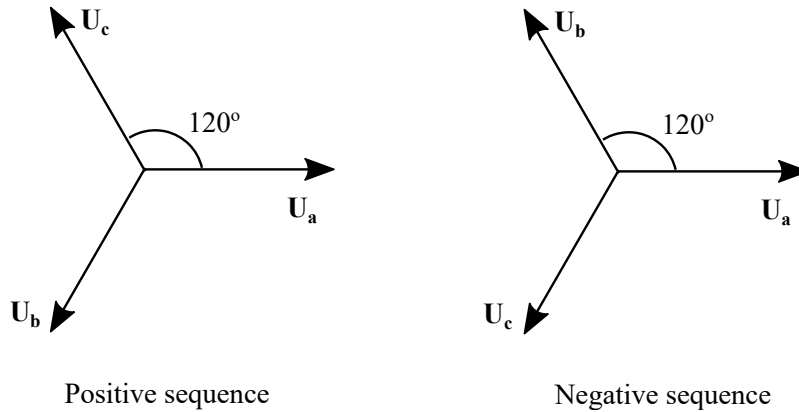

It is important to note that the sum of three sinusoidal functions of the same amplitude and relative phase shift  $120^\circ$  is zero:

$$u_a + u_b + u_c = 0 \quad (7)$$

That statement is also valid for the phasors that represent the sinusoidal functions:

$$\underline{U}_a + \underline{U}_b + \underline{U}_c = 0 \quad (8)$$

## 1.2 Three-phase loads

Three-phase loads can be represented, in the frequency domain, as a set of three impedances connected between them. We will limit our analysis to systems in which the impedance connected to each phase has the same value; this is the most common situation in power systems. As with generators, the three-phase loads may be connected in wye or delta:

Wye connection

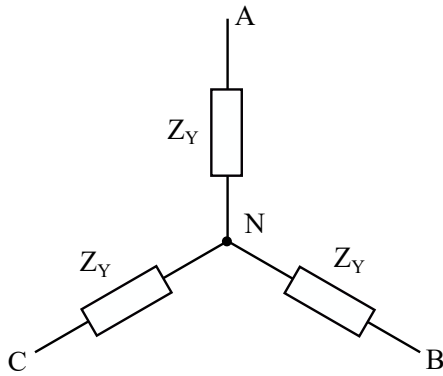

Delta connection

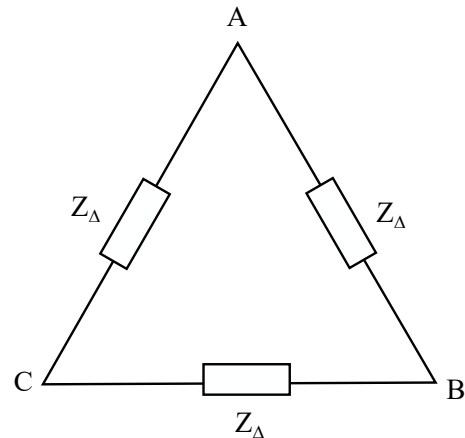

### 1.3 Balanced three phase systems

The analysis of this course is restricted to balanced systems; in those systems the amplitude of the voltages and the impedance of the load in the three phases is the same.

The figure below represent a three phase wye-wye system, as the three impedances and the three generators share one terminal while the other terminal is connected to the system. In wye wye systems the neutral points of the generators (N) and the loads (N') might be connected by means of a **neutral wire** forming a four-wire configuration. In this case, the current of each phase flows from the generator towards the load (i.e in phase A the load flows from A to A') and returns through the neutral wire and the the neutral wire carries the sum of currents  $\underline{I}_a$ ,  $\underline{I}_b$  and  $\underline{I}_c$

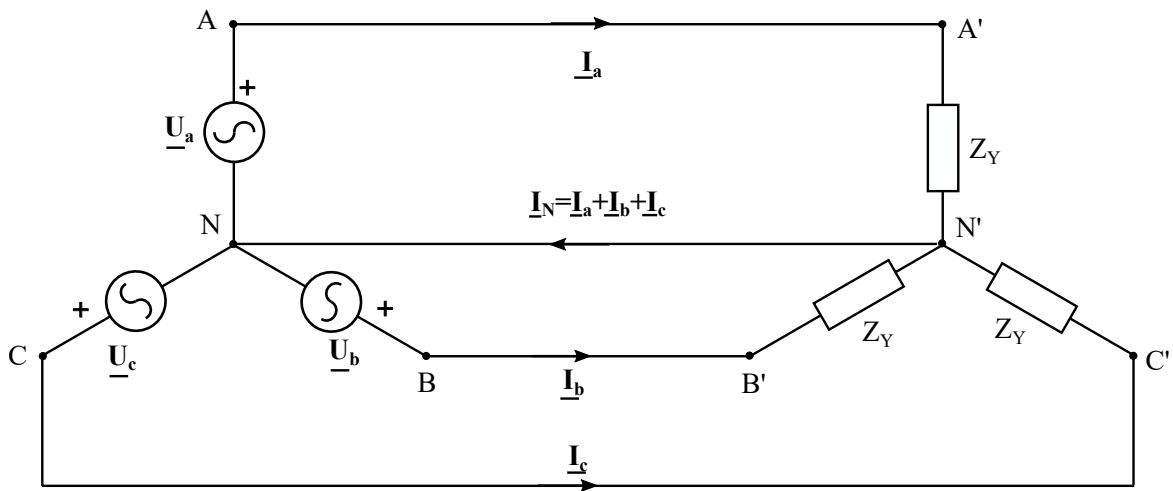

In the circuit of the figure, the currents that circulate through the three phases are:

$$\underline{I}_a = \frac{\underline{U}_a}{Z_Y} = \frac{U \angle 0^\circ}{Z_Y} \quad \underline{I}_b = \frac{\underline{U}_b}{Z_Y} = \frac{U \angle 120^\circ}{Z_Y} \quad \underline{I}_c = \frac{\underline{U}_c}{Z_Y} = \frac{U \angle 240^\circ}{Z_Y}$$

Note that the currents of the three phases also form a balanced three-phase system of currents (three currents of the same modulus and relative phase shift  $120^\circ$ ). If the impedances are  $Z_Y = jZ_Y \angle \theta$ , the phasor diagram of the system for inductive loads and capacitive loads is:

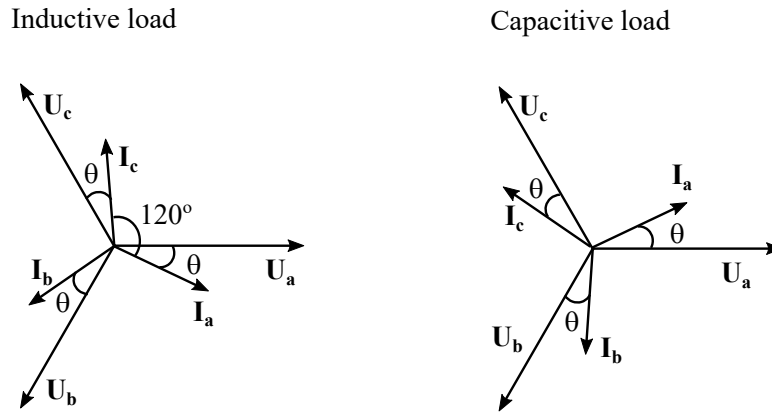

The current that flows through the neutral is the sum of  $I_a$ ,  $I_b$ , and  $I_c$ ; however, as the three currents form a balanced three phase system (i.e. they have the same magnitude and relative phase-shift  $120^\circ$ ), the current that flows through the neutral is zero:

$$\underline{I}_N = \underline{I}_a + \underline{I}_b + \underline{I}_c = \frac{U}{Z_Y} (1 \angle 0 + 1 \angle -120^\circ + 1 \angle 120^\circ) = 0 \quad (9)$$

From a practical point of view, the fact that no current flows through the neutral wire implies that this conductor is suppressed in many occasions, moving towards a three wire system as the one shown in the figure below. The suppression of the neutral wire implies a significant reduction in the system construction and management costs (i.e. investment in materials, infrastructure building, maintenance costs):

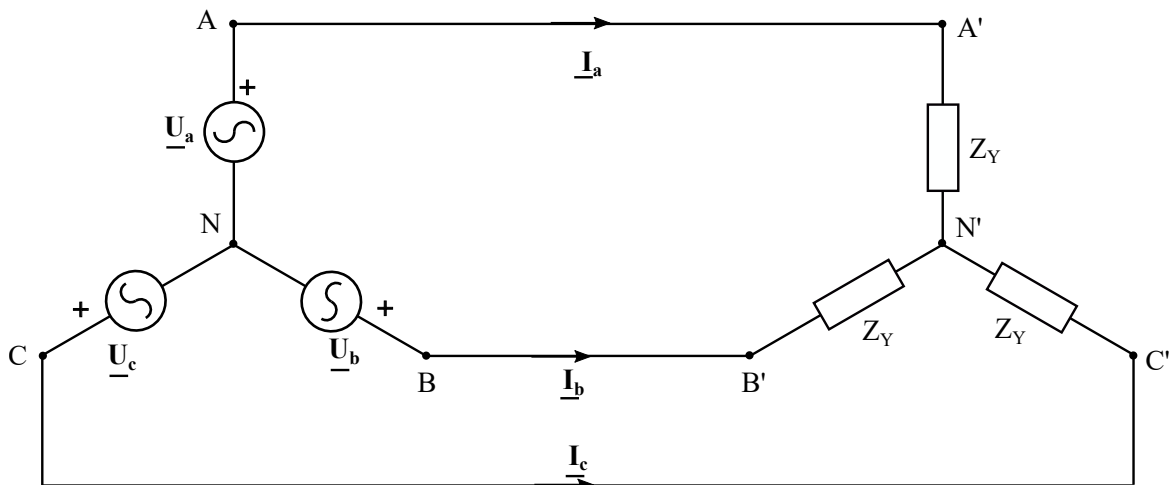

## 2 Voltages and currents in three-phase systems

### 2.1 Nomenclature: phase and line magnitudes

Before introducing the methodology that will be applied to the analysis of three phase systems, we need to define some nomenclature:

- **Phase-voltage:** Voltage drop across a single phase of the generator or the load. The phase-voltage of the generator ( $U_{\text{PHASE GEN}}$  in the diagram) is the voltage drop across the terminals of one of the ideal voltage sources; the phase voltage of the load ( $U_{\text{PHASE LOAD}}$  in the diagram) is the voltage drop across one of the impedances that constitutes the load.
- **Line-voltage:** Voltage drop between any couple of lines. We could obtain the line voltage at the generator side of the system ( $U_{\text{LINE GEN}}$  in the diagram), or the line voltage at the load side ( $U_{\text{LINE LOAD}}$ ).
- **Phase current:** Current in a single phase, i.e current flowing through one of the ideal sources or through one of the impedances ( $I_{\text{PHASE GEN}}$ ,  $I_{\text{PHASE LOAD}}$ ).
- **Line current:** Current in a single line ( $I_{\text{LINE}}$  in the diagram).

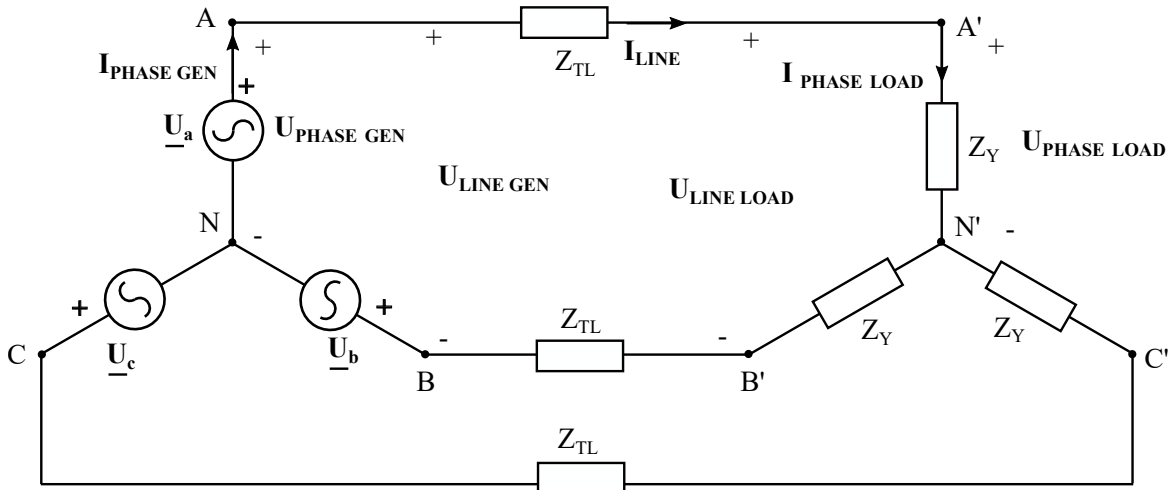

### 2.2 Relation between the line and phase magnitudes in a wye-wye system

The system in the previous figure represents a wye connected three-phase generator that supplies energy to a wye connected three phase load.

Applying KCL to the different nodes of the circuit it can be seen that for the three phases:

$$\underline{I}_L = \underline{I}_{Ph} \quad (10)$$

Regarding the phase voltage and line voltage across at the generator side of the system:

$$\underline{U}_{Pha} = \underline{U}_a \quad \underline{U}_{Phb} = \underline{U}_b \quad \underline{U}_{Phc} = \underline{U}_c \quad (11)$$

And the line voltages are:

$$\underline{U}_{La} = \underline{U}_{AB} = \underline{U}_a \quad \underline{U}_b = U \angle 120^\circ = \frac{\rho}{3} U \angle 30^\circ = \frac{\rho}{3} \underline{U}_{Pha} \angle 30^\circ \quad (12)$$

$$\underline{U}_{Lb} = \underline{U}_{BC} = \underline{U}_b \quad \underline{U}_c = \frac{\rho}{3} \underline{U}_{Phb} \angle 30^\circ \quad (13)$$

$$\underline{U}_{Lc} = \underline{U}_{CA} = \underline{U}_c \quad \underline{U}_a = \frac{\rho}{3} \underline{U}_{Phc} \angle 30^\circ \quad (14)$$

The same relations between the line and phase magnitudes are valid for the load end of the system if the load is wye connected.

The relation between the phase and line voltages can be also derived using the phasor-diagram:

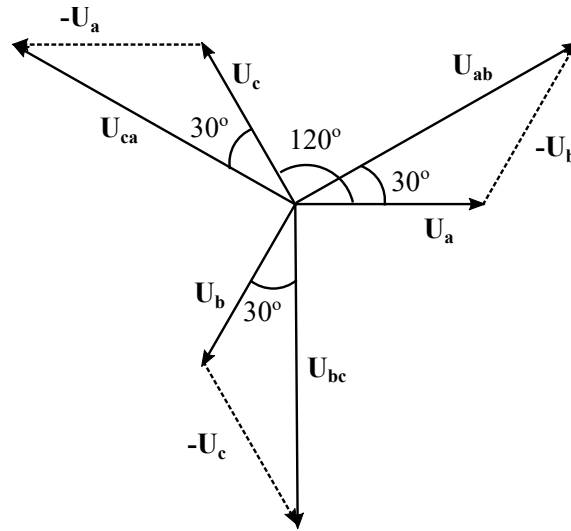

### 2.3 Relation between the line and phase magnitudes in a delta-delta system

If we now consider a delta-delta system <sup>1</sup> and determine its phase and line voltages and currents:

<sup>1</sup>For the sake of simplicity we consider that the impedance in the transmission line is zero

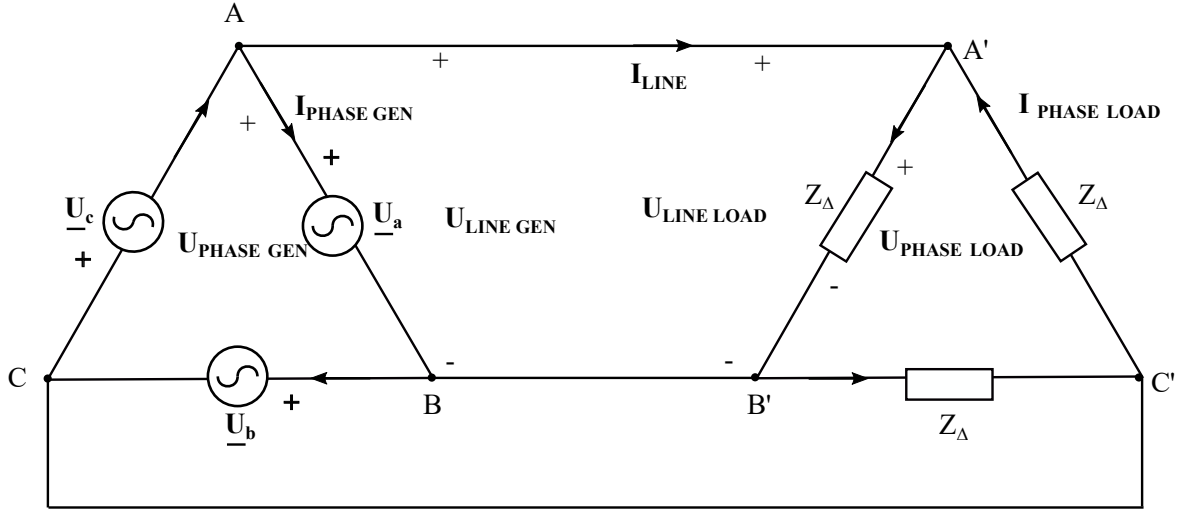

We see that in this case the phase and line voltages of each phase are the same.

$$\underline{U}_{LINE} = \underline{U}_{PHASE} \quad (15)$$

The phase-currents in the load are:

$$\underline{I}_{Pha} = \underline{I}_{B^0C^0} = \frac{\underline{U}_a}{Z} = \frac{U \angle 0}{Z} \quad (16)$$

$$\underline{I}_{Phb} = \underline{I}_{A^0B^0} = \frac{\underline{U}_b}{Z} = \frac{U \angle 120^\circ}{Z} \quad (17)$$

$$\underline{I}_{Phc} = \underline{I}_{C^0A^0} = \frac{\underline{U}_c}{Z} = \frac{U \angle 120^\circ}{Z} \quad (18)$$

And the line-current can be obtained using KCL:

$$\underline{I}_{La} = \underline{I}_{Pha} \quad \underline{I}_{Phb} = \frac{U \angle 0}{Z} \quad \frac{U \angle 120^\circ}{Z} = \frac{\rho}{\sqrt{3}} \frac{U}{Z} \angle 30^\circ = \frac{\rho}{\sqrt{3}} \underline{I}_{Pha} \angle 30^\circ \quad (19)$$

$$\underline{I}_{Lb} = \frac{\rho}{\sqrt{3}} \underline{I}_{Phb} \angle 30^\circ \quad (20)$$

$$\underline{I}_{Lc} = \frac{\rho}{\sqrt{3}} \underline{I}_{Phc} \angle 30^\circ \quad (21)$$



### 3 Analysis of three-phase systems: one-phase equivalent circuit

#### 3.1 One-phase equivalent

Lets imagine a wye-wye balanced three-phase system where the load is connected with the generator by means of a transmission line of impedance  $Z_{TL}$

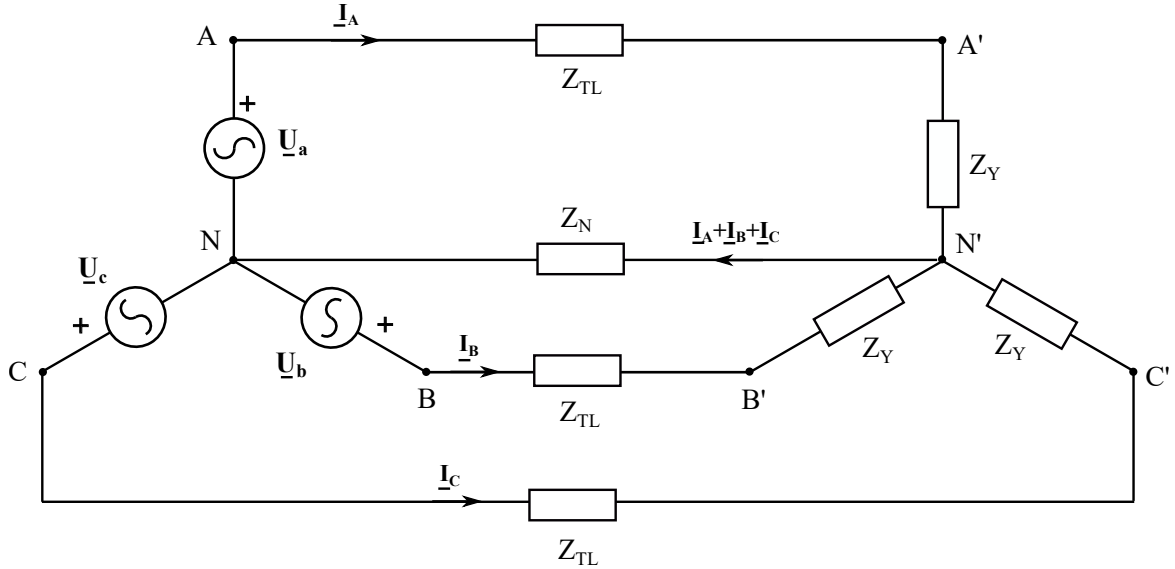

We could apply KVL to the three mesh of the circuit:

$$\underline{U}_a + \underline{I}_a (Z_{TL} + Z_Y) + (\underline{I}_a + \underline{I}_b + \underline{I}_c) Z_N = 0 \quad (22)$$

$$\underline{U}_b + \underline{I}_b (Z_{TL} + Z_Y) + (\underline{I}_a + \underline{I}_b + \underline{I}_c) Z_N = 0 \quad (23)$$

$$\underline{U}_c + \underline{I}_c (Z_{TL} + Z_Y) + (\underline{I}_a + \underline{I}_b + \underline{I}_c) Z_N = 0 \quad (24)$$

Given that  $\underline{I}_a + \underline{I}_b + \underline{I}_c = 0$  the equations result:

$$\underline{U}_a + \underline{I}_a (Z_{TL} + Z_Y) = 0 \quad (25)$$

$$\underline{U}_b + \underline{I}_b (Z_{TL} + Z_Y) = 0 \quad (26)$$

$$\underline{U}_c + \underline{I}_c (Z_{TL} + Z_Y) = 0 \quad (27)$$

As the total current flowing through the neutral wire is zero, the obtained equations are identical to the ones that would be found if the three independent circuits shown below were analysed:

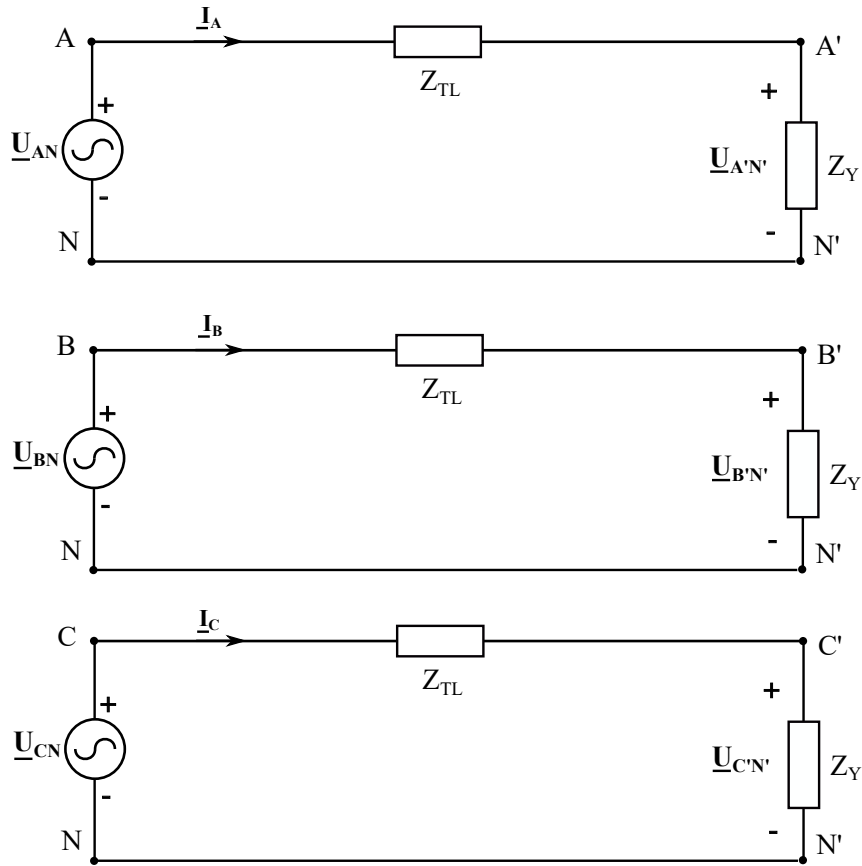

Moreover, as the system is balanced, the electric magnitudes of the three phases have the same amplitude and a known phase shift ( $120^\circ$ ). Then, the behaviour of the whole system could be derived from the analysis of the following one-phase system shown below. This is the so called **one-phase equivalent** or **phase-neutral equivalent** of the system.

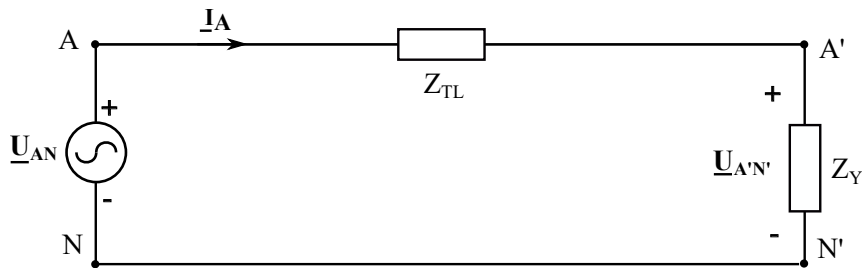

### Example

In the circuit of the figure  $U_L = 380V$ ,  $Z_{TL} = 1 + j\Omega$  and  $Z_Y = 50 + 50j\Omega$  per phase. Calculate the line current, the line voltage at the load side of the system and the voltage drop across the transmission line

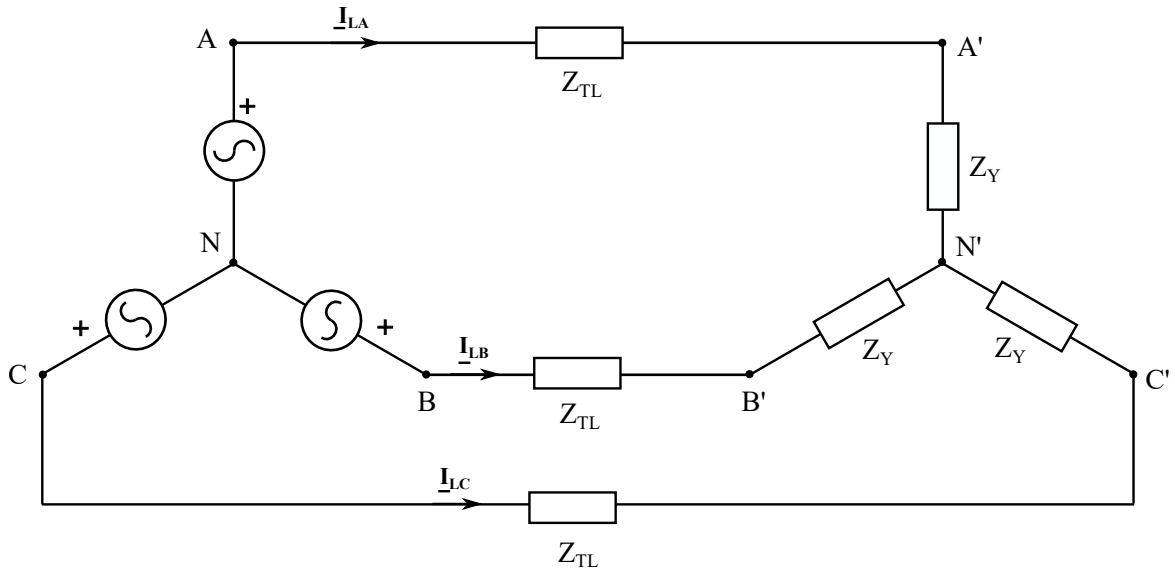

### Solution

The problem can be solved with the one-phase equivalent approach. We study what happens in phase A and extrapolate the variables of the other phases.

The problem only indicate the magnitude of the line voltage (not the phase), so we can choose any phase origin. We take the phase voltage of phase A as phase origin:  $\underline{U}_{AN} = \frac{380}{\sqrt{3}} \angle 0^\circ$

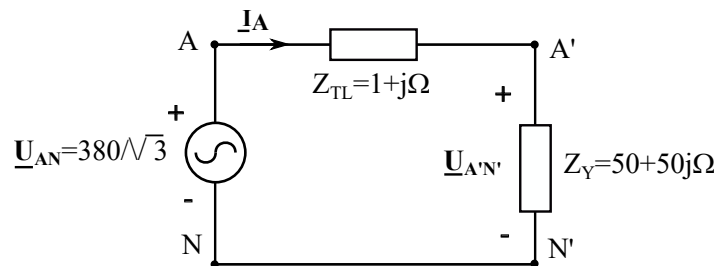

$$\underline{I}_A = \frac{\underline{U}_{AN}}{Z_{TL} + Z_Y} = 1.83 - 1.83j = 2.59 \angle -45^\circ A$$

For the other phases the currents are:

$$\underline{I}_B = 2.59 \angle -45 - 120 = 2.59 \angle -165^\circ A$$

$$\underline{I}_C = 2.59 \angle -45 + 120 = 2.59 \angle 75^\circ A$$

Voltages at the load end of the system:

$$\underline{U}_{A'N'} = \underline{I}_A Z_Y = 182.83 \angle 0^\circ V$$

Line voltage:

$$U_{L_{load}} = U_{ph_{load}} \frac{\rho_-}{3} = 316.66V$$

Phasors line voltage at the load end of the system:

$$\underline{U}_{A^0B^0} = 316.66 \angle 30^\circ V$$

$$\underline{U}_{B^0C^0} = 316.66 \angle 90^\circ V$$

$$\underline{U}_{C^0A^0} = 316.66 \angle 150^\circ V$$

Voltage drop across the transmission line:

$$\underline{U}_{AA^0} = \underline{I}_A Z_{TL} = 36.56 \angle 0^\circ V$$

$$\Delta U_{TL} = 36.56V$$

### 3.2 Analysis of systems with delta-connected loads or generators

The application of the one-phase equivalent is not possible in systems in which the generator or the load are in delta. However we can always replace the delta configuration by an equivalent wye.

#### 3.2.1 Delta-connected generators

Three delta-connected generators can be redrawn as an **equivalent** wye configuration:

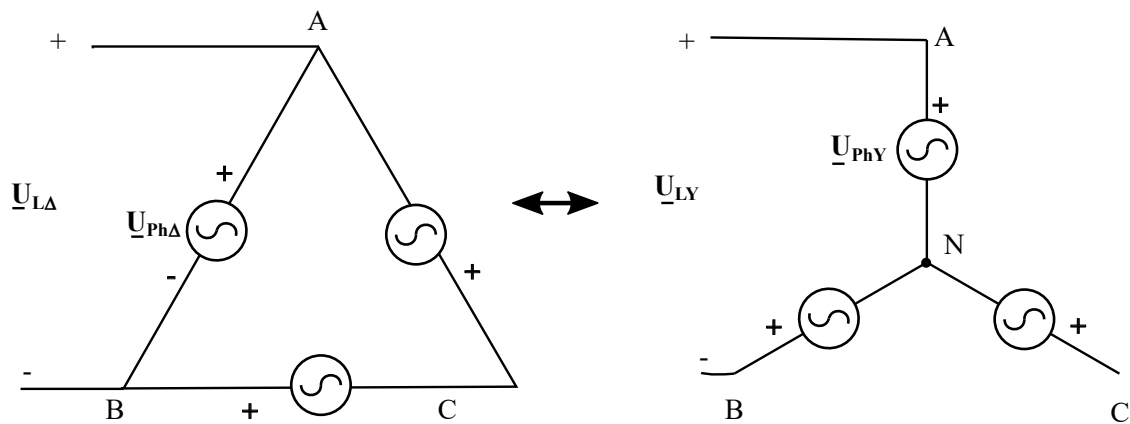

The two configurations are equivalent if the line voltages are the same for both of them:

$$\underline{U}_{LY} = \underline{U}_L \quad (28)$$

As can be seen in the diagram, the phase voltages of the delta and wye generators will be different.

$$\underline{U}_{PhY} = \frac{\underline{U}}{\sqrt{3}} \angle -30^\circ \quad (29)$$

### 3.2.2 Delta connected loads: wye delta equivalent

We want to find what should be the value of  $Z_Y$  that makes the two loads in the figure equivalent.

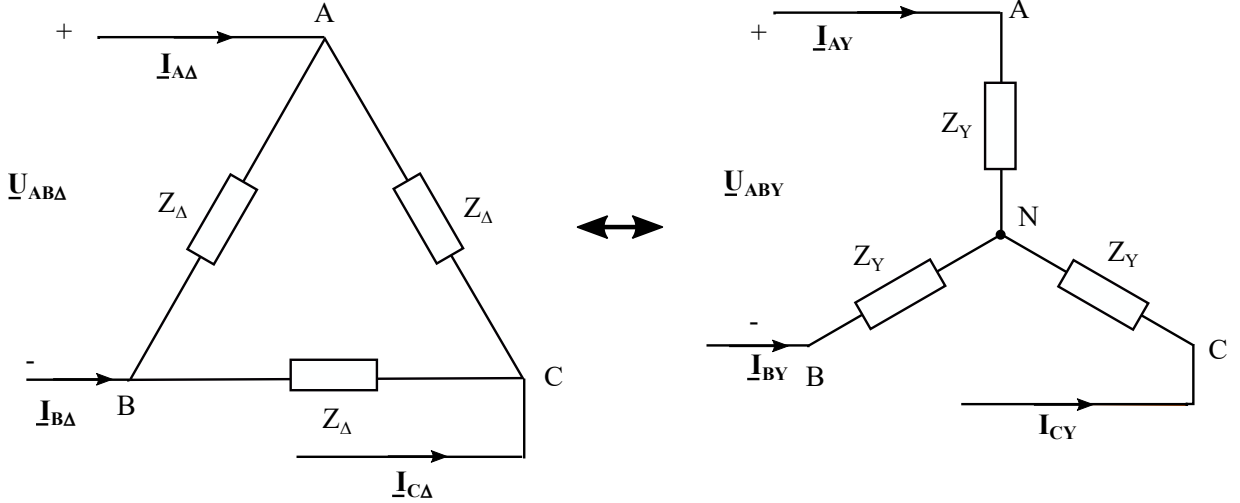

The loads are equivalent if for the same applied line voltages:

$$\underline{U}_{AB} = \underline{U}_{ABY} \quad \underline{U}_{BC} = \underline{U}_{BCY} \quad \underline{U}_{CA} = \underline{U}_{CA Y} \quad (30)$$

the line currents are the same:

$$\underline{I}_A = \underline{I}_{AY} \quad \underline{I}_B = \underline{I}_{BY} \quad \underline{I}_C = \underline{I}_{CY} \quad (31)$$

We can limit our analysis to one phase, since the behaviour in the three phases is the same except that there is a phase shift of  $120^\circ$

$$\underline{I}_A = \frac{\rho}{\sqrt{3}} \underline{I}_{PhA} \angle -30^\circ = \frac{\underline{U}_{AB}}{Z} \frac{\rho}{\sqrt{3}} \angle -30^\circ \quad (32)$$

$$\underline{I}_{AY} = \underline{I}_{PhA} = \frac{\underline{U}_{AB} / \frac{\rho}{\sqrt{3}} \angle -30^\circ}{Z_Y} \quad (33)$$

We determine for what value of the impedance  $Z_Y$  the identity  $\underline{I}_A = \underline{I}_{AY}$  is true

$$\frac{\underline{U}_{AB}}{Z} \frac{\rho}{\sqrt{3}} \angle -30^\circ = \frac{\underline{U}_{AB} / \frac{\rho}{\sqrt{3}} \angle -30^\circ}{Z_Y} \quad (34)$$

finding that:

$$Z_Y = \frac{Z}{3} \quad (35)$$

### 3.2.3 One-phase equivalent for systems with delta connected-elements

In systems with a delta-connected loads or delta-connected generator wye-delta transformations must be applied to obtain a YY connected system equivalent to the original where we can use the one-phase equivalent approach.

In  $Y\Delta$  or  $\Delta\Delta$  or  $\Delta Y$  systems:

1. The system is transformed into a YY equivalent system.
2. The one-phase equivalent approach is applied over the YY equivalent circuit and the line variables of the system are calculated.
3. We return to the original system and calculate the remaining variables.

#### Example

In the following circuit, the load is supplied with line-voltage 400 V. Knowing that  $Z_{TL} = 1 + 4j\Omega$ ,  $Z_{\Delta} = 30 + 60j\Omega$ . Calculate the line currents and the phase currents and the line voltage at the generator end of the system.

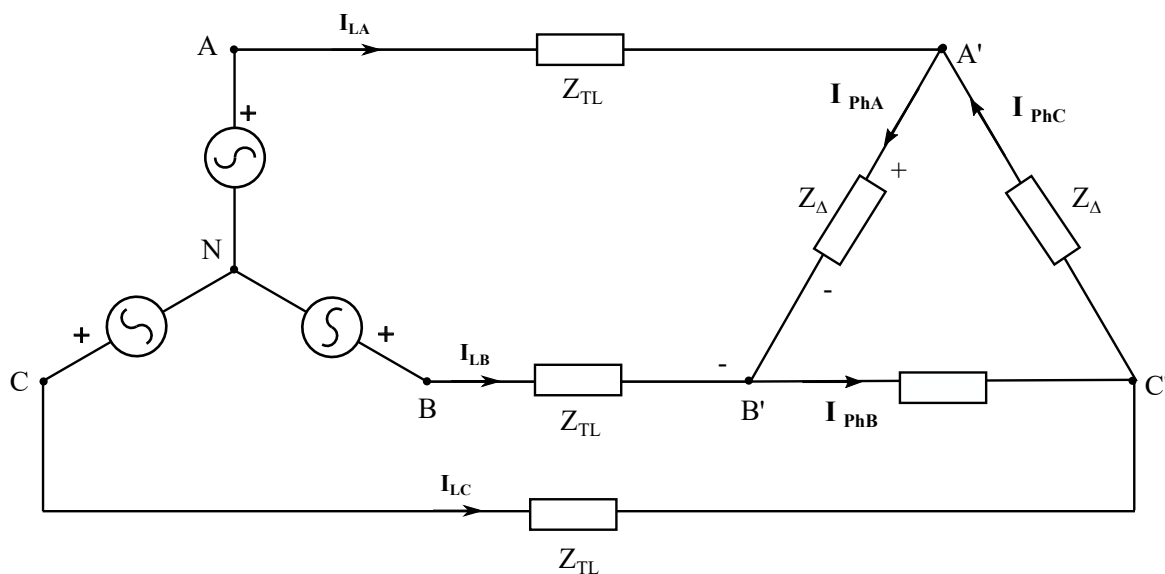

#### Solution

We transform the original system into a YY equivalent circuit. As the systems are equivalent, the line voltages and line currents remain unchanged.

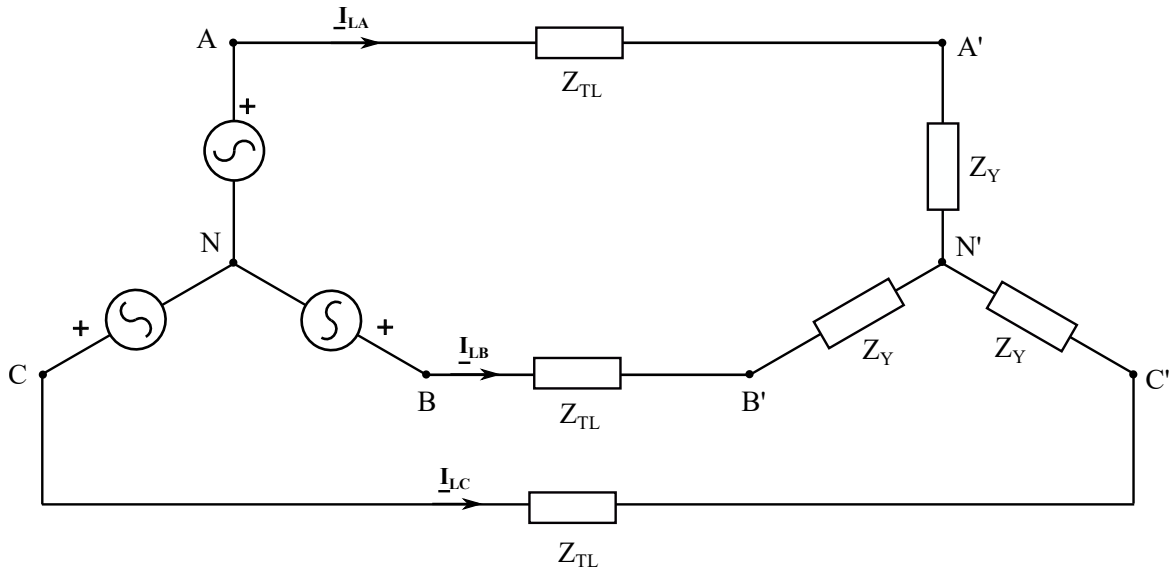

The impedances in Y are:

$$Z_Y = \frac{Z}{3} = 10 + 20j\Omega$$

and the line voltage at the load end is 400 V.

The one-phase equivalent of the system is:

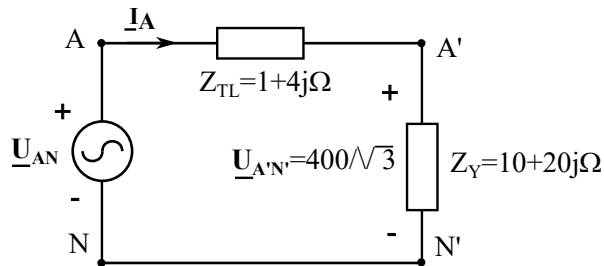

In this case we take the phase voltage at the load end of the system as phase origin for the sake of simplicity.

$$\underline{I}_A = \frac{\underline{U}_{A'N}}{Z_Y} = 4.62 - 9.24j = 10.33 \angle -63.43^\circ A$$

For the other phases the line currents are:

$$\underline{I}_B = 10.33 \angle -63.43 - 120 = 10.33 \angle -183.43^\circ A$$

$$\underline{I}_C = 10.33 \angle -63.43 + 120 = 10.33 \angle 56.56^\circ A$$

The line currents are the same for the YY and the YΔ circuits. The phase currents for the original system are:

$$\underline{I}_{phA} = \frac{\underline{I}_B}{\sqrt{3}} \angle 30^\circ = 5.96 \angle 33.43^\circ A$$

and for the other phases:

$$\underline{I}_{phB} = 5.96 \angle 153.43^\circ A$$

$$\underline{I}_{phC} = 5.96 \angle 86.57^\circ A$$

Phase voltage at the generator end of the system:

$$\underline{U}_{AN} = \underline{I}_A Z_{TL} + \underline{U}_{A^0N^0} = 272.66 \angle 1.94^\circ V$$

Line voltage at the generator:

$$U_{L_g} = U_{phg} \sqrt{3} = 472.27V$$

Phasors line voltage at the load end of the system:

$$\underline{U}_{A^0B^0} = 472.27 \angle 1.94 + 30^\circ V = 472.27 \angle 31.94^\circ V$$

$$\underline{U}_{B^0C^0} = 472.27 \angle 88.06^\circ V$$

$$\underline{U}_{C^0A^0} = 472.27 \angle 151.94^\circ V$$

Voltage drop across the transmission line:

$$\underline{U}_{AA^0} = \underline{I}_A Z_{TL} = 42.58 \angle 12.53^\circ V$$

$$\Delta U_{TL} = 42.58V$$

## 4 Power in three-phase circuits

### 4.1 Instantaneous power

To calculate the instantaneous power of a three phase load or generator, we must add the power of each phase.

$$p(t) = u_a(t) i_a(t) + u_b(t) i_b(t) + u_c(t) i_c(t) \quad (36)$$

In a three phase system were:

$$u_a(t) = \frac{\sqrt{2}}{2} U \cos(\omega t)$$



$$u_b(t) = \frac{\rho_-}{2} U \cos(\omega t - 120^\circ)$$

$$u_c(t) = \frac{\rho_-}{2} U \cos(\omega t + 120^\circ)$$

and

$$i_a(t) = \frac{\rho_-}{2} I \cos(\omega t - \varphi)$$

$$i_b(t) = \frac{\rho_-}{2} I \cos(\omega t - 120^\circ - \varphi)$$

$$i_c(t) = \frac{\rho_-}{2} I \cos(\omega t + 120^\circ - \varphi)$$

$$p(t) = 2 U I (\cos(\omega t) \cos(\omega t - \varphi) + \cos(\omega t - 120^\circ) \cos(\omega t - 120^\circ - \varphi) + \cos(\omega t + 120^\circ) \cos(\omega t + 120^\circ - \varphi))$$

applying:

$$\cos \alpha \cos \beta = \frac{1}{2} (\cos(\alpha + \beta) + \cos(\alpha - \beta)) \quad (37)$$

$$p(t) = U I (3 \cos \varphi + \underbrace{\cos(2\omega t - \varphi) + \cos(2\omega t - 120^\circ - \varphi) + \cos(2\omega t + 120^\circ - \varphi)}_0)$$

Since the sum of three sinusoidal functions with relative phase shift  $120^\circ$  is zero we find that the instantaneous power of a three phase system is constant and depends on the amplitude of the current, the amplitude of the voltage and the power factor:

$$p(t) = 3 U I \cos \varphi \quad (38)$$

The fact that the three-phase instantaneous power is constant has practical implications, as the fact that vibrations in the axles of three phase motors and generators are smaller than those in one-phase devices. This makes them more stable from the mechanical point of view, improve their reliability and extend their service life.

## 4.2 Active and reactive power of a three-phase load

### 4.2.1 Wye-connected systems

Lets consider a three-phase load with impedance per phase  $Z_Y = jZY \angle \theta$

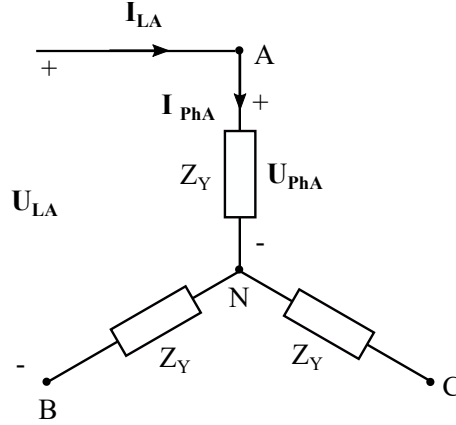

The active power absorbed by the load is the sum of the active power absorbed by each individual impedance:

$$P = P_A + P_B + P_C \quad (39)$$

where

$$P_A = U_{PhA} I_{PhA} \cos \varphi \quad P_B = U_{PhB} I_{PhB} \cos \varphi \quad P_C = U_{PhC} I_{PhC} \cos \varphi$$

as the three phase voltages and the three phase currents have the same magnitude (U):

$$P_A = P_B = P_C = U_{Ph} I_{Ph} \cos \varphi \quad (40)$$

The total active power is:

$$P = 3 U_{Ph} I_{Ph} \cos \varphi \quad (41)$$

The power can also be expressed as a function of the line magnitudes. As in Y  $I_L = I_{Ph}$  and  $U_{Ph} = U_L / \sqrt{3}$ :

$$P = \sqrt{3} U_L I_L \cos \varphi \quad (42)$$

Equations (41) and (42) are also valid to calculate the active power of Y-connected generators.

Following the same reasoning we can find equations to calculate the reactive power of a wye-connected load or generator:

$$Q = 3 U_{Ph} I_{Ph} \sin \varphi = \sqrt{3} U_L I_L \sin \varphi \quad (43)$$

#### 4.2.2 Delta connected systems

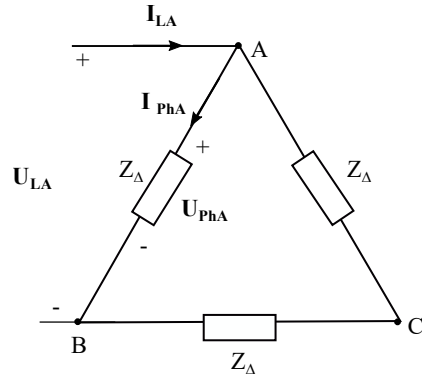

For delta-connected loads and generators we can still apply:

$$P = 3 U_{Ph} I_{Ph} \cos \varphi \quad (44)$$

$$Q = 3 U_{Ph} I_{Ph} \sin \varphi \quad (45)$$

To express the active and reactive power as a function of the line magnitudes we consider the relations between phase and line magnitudes in delta systems:  $U_L = U_{Ph}$  and  $I_{Ph} = I_L / \sqrt{3}$ :

$$P = \sqrt{3} U_L I_L \cos \varphi \quad (46)$$

$$Q = \sqrt{3} U_L I_L \sin \varphi \quad (47)$$

#### 4.2.3 General expressions for the active and reactive power of a three-phase system

From the previous reasoning it can be concluded that the expressions to calculate the active and reactive power of a three-phase are the same for wye and delta systems and are:

$$P = 3 U_{Ph} I_{Ph} \cos \varphi = \sqrt{3} U_L I_L \cos \varphi \quad (48)$$

$$Q = 3 U_{Ph} I_{Ph} \sin \varphi = \sqrt{3} U_L I_L \sin \varphi \quad (49)$$

#### 4.3 Complex power of three phase generators

The complex power of a three-phase generator, connected in wye or delta, is the sum of the complex power of the three phases:

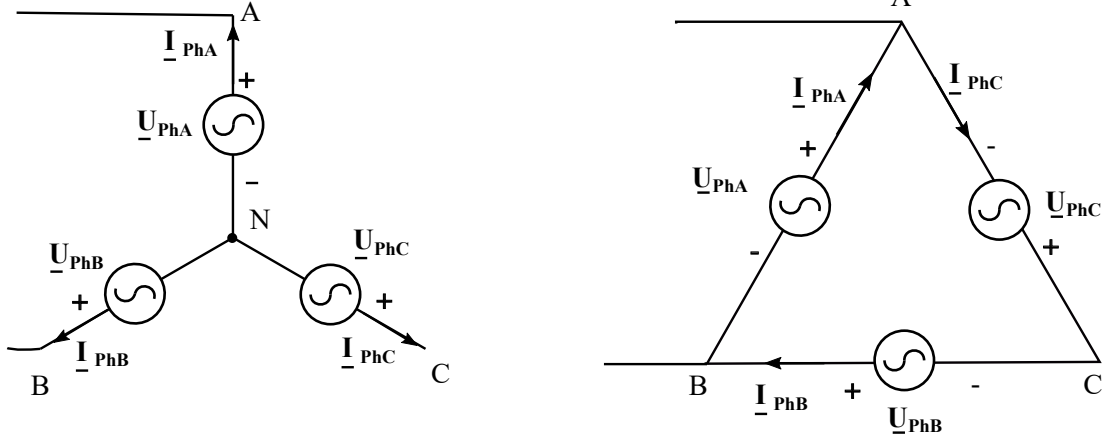

$$S_g = \underline{U}_{PhA} \underline{I}_{PhA} + \underline{U}_{PhB} \underline{I}_{PhB} + \underline{U}_{PhC} \underline{I}_{PhC} = 3 \underline{U}_{PhA} \underline{I}_{PhA} \quad (50)$$

## 5 Power factor correction

### 5.1 Power factor

To characterize an AC load it is necessary to specify its rated power but also its power factor. The power factor provides information about the proportion between the active power and reactive power absorbed by it.

$$p.f. = \cos \varphi \quad (51)$$

The angle  $\varphi$  may be expressed as the phase-shift between the current and the voltage across the impedance, the arch-tangent of the ratio between  $Q$  and  $P$  and the angle of the complex impedance:

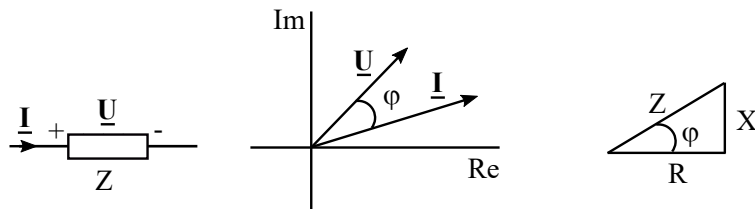

$$\varphi = \varphi_u \quad \varphi_i = \arctan \frac{Q}{P} = \arctan \frac{X}{R} \quad (52)$$

If  $\varphi > 0$  we say that the power factor is **lagging** or that it is **inductive**, if  $\varphi < 0$  the power factor is **leading** or **capacitive**.

The following table summarizes the values of the reactive power and power factors of the different types of loads. Resistive systems have power factor 1, what means that there is no absorption of reactive power.

	$Q$	$\varphi$	$\cos \varphi$	character
<b>Resistive loads</b>	0	0	1	-
<b>Inductive loads</b>	$> 0$	$> 0$	$0 < p.f < 1$	lagging or inductive
<b>Capacitive loads</b>	$< 0$	$< 0$	$0 < p.f < 1$	leading or capacitive

## 5.2 Reactive power compensation

In AC systems there is a continuous exchange of energy between generators and capacitive and inductive loads. The amplitude of the fluctuating power is defined as the **reactive power** and is of different sign in both types of elements. As inductors absorb reactive power ( $Q_L > 0$ ) capacitors deliver reactive power ( $Q_C < 0$ ).

Many real-life loads, as electric motors, are highly inductive and it is common that the operation of power systems electric systems involve high amounts of reactive power transferred from the generators towards the loads. The fluctuating power increases the current flowing through the lines what impacts in the system losses and causes voltage drops. For that reason, electric companies penalize the costumers that consume power with poor power factor.

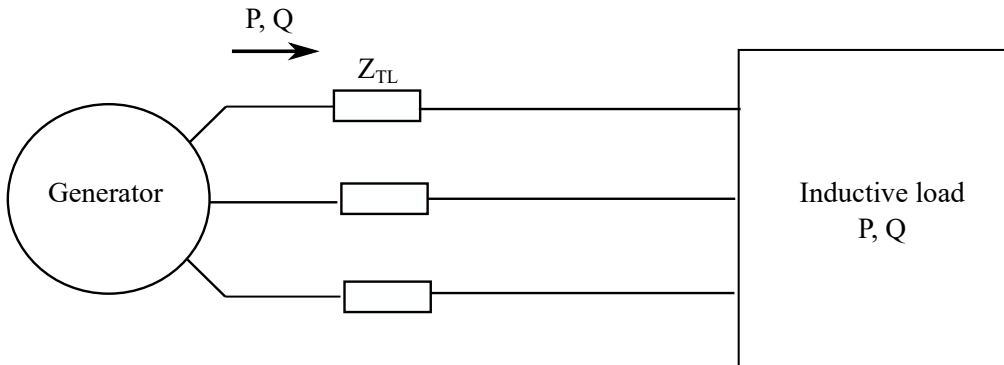

The solution given to this problem by the industry consists of adding banks of capacitors in parallel with the loads, to compensate part of the reactive power absorbed by them. In this case the generator only supplies a portion of the reactive power demanded by the load while the most of the required reactive power is delivered by the capacitors:

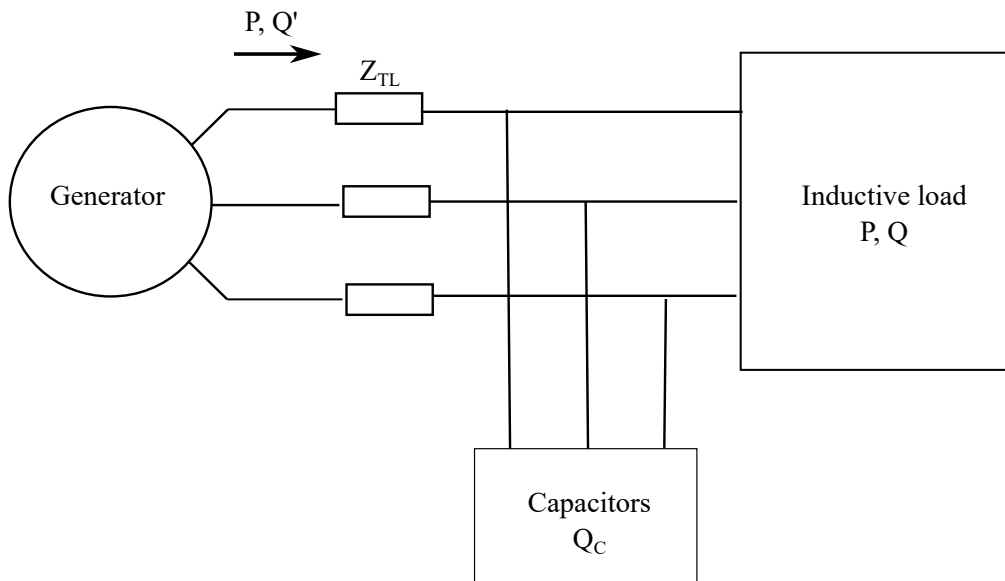

It is important to note that capacitors do not absorb or deliver any active power, so the active power of the system remains unchanged despite of connecting them.

If the powers are plotted in a power triangle (the active and reactive power absorption in the line are neglected in the reasoning for simplicity's shake), we see how the relation between the active and reactive power changes and the angle  $\varphi^l$  becomes smaller if the capacitors are added to the system:

Initial system

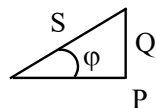

System with capacitors

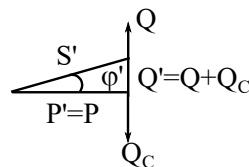

The reactive power delivered by the generator if the capacitors are added is:

$$Q^l = Q + Q_C \tag{53}$$

### 5.3 Determination of the capacitance of the capacitor bank

#### 5.3.1 Reactive power of a capacitor

If we have a capacitor of capacitance  $C$  and with a voltage drop  $\underline{U} = U \angle \varphi_U$  and current flow  $\underline{I} = I \angle \varphi_I$ :

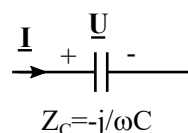

Its reactive power is:

$$Q_C = X_C I^2 = \frac{U^2}{X_C} = \omega C U^2 \quad (54)$$

### 5.3.2 Reactive power of a bank of capacitors in wye

The total reactive power of a bank of capacitors connected in wye is the sum of the reactive power of the three capacitors and can be expressed as a function of the phase voltage or the line voltage

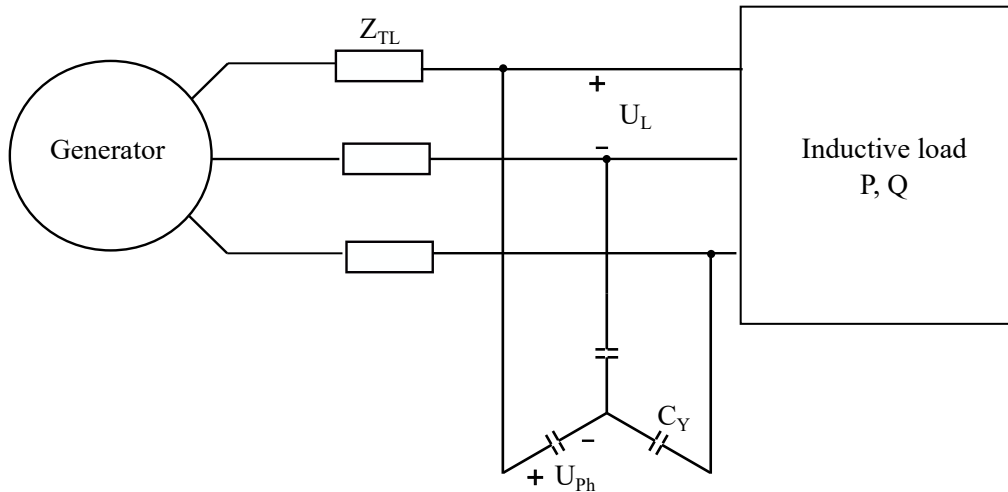

$$Q_{CY} = 3 \omega C_Y \underbrace{U_{Ph}^2}_{U_L = \sqrt{3} U_{Ph}} = \omega C_Y U_L^2 \quad (55)$$

### 5.3.3 Reactive power of a bank of capacitors in delta

If the capacitors are delta connected the expression of the power in terms of the phase voltage is the same but if it is expressed as a function of the line voltage, we see that for the same capacitors we extract three times more power if they are connected in delta. For this reason this is the most commonly used configuration for the capacitor banks that are used for power compensation purposes.

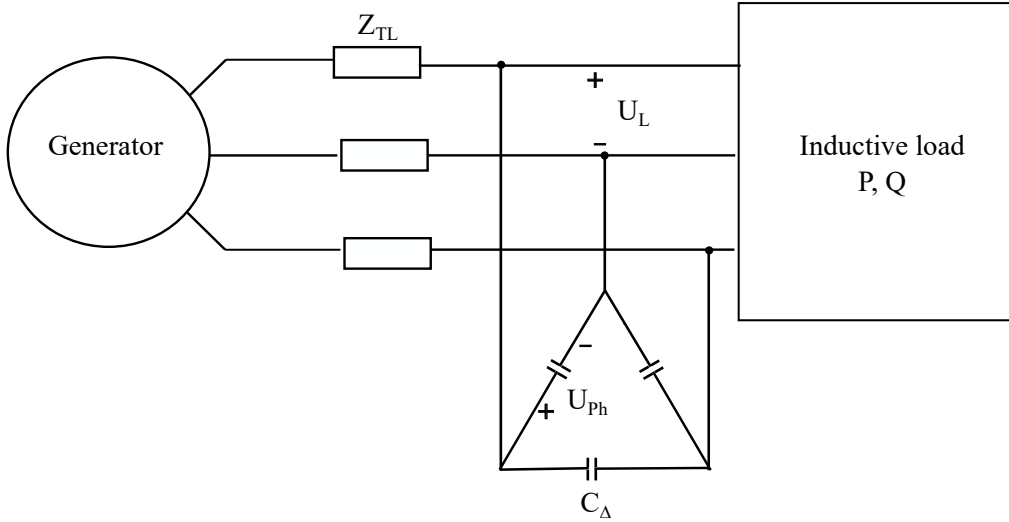

$$Q_C = 3 \omega C \underbrace{U_{Ph}^2}_{U_L^2} = 3 \omega C U_L^2 \quad (56)$$

### 5.3.4 Capacitance required to get a target value for the power factor

If we have a system that it is working with power factor  $\cos \varphi$  and we want to compensate the reactive power so that the power factor is corrected to  $\cos \varphi^\theta$ , as in the next diagram:

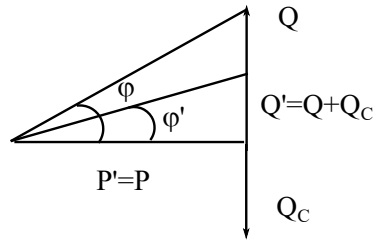

$$Q = P \tan \varphi \quad Q^\theta = P \tan \varphi^\theta \quad (57)$$

$$Q_C = Q - Q^\theta = P (\tan \varphi - \tan \varphi^\theta) \quad (58)$$

Then, if the capacitors are  $\Delta$ -connected:

$$C = \frac{P (\tan \varphi - \tan \varphi^\theta)}{3 \omega U_L^2} \quad (59)$$

And, if the capacitors are Y-connected:

$$C_Y = \frac{P (\tan \varphi - \tan \varphi^\theta)}{\omega U_L^2} \quad (60)$$



## 6 Measure of power in three-phase systems

### 6.1 Working principle of wattmeters

A wattmeter is a measuring device that provides information on the power absorbed by electric dipoles. Wattmeters incorporate two measuring circuits: one to measure the current, the current coil, and another to measure the voltage, the voltage coil. The current coil must be connected in series with the dipole, while the voltage coil is connected in parallel with it. Two signs \* mark the terminals of the current and voltage coil of the same relative polarity:

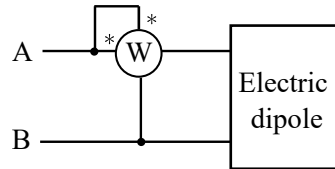

The reading of the wattmeter of the figure is:

$$W = I_A U_{AB} \cos(\underline{U}_{AB} \underline{I}_A) \quad (61)$$

In three phase systems wattmeters may be connected in different ways to measure the power; the connection form depends on the configuration of the system that is being characterized and the variable that is searched. The following subsections provide some examples for connections that are used in real systems to measure the active and reactive power of three phase systems.

### 6.2 Measure of the active power in systems with accessible neutral point

In the system in the figure, the wattmeter is measuring the active power of the impedance in phase A. The active power of the three phase load is calculated as  $3 W$ .

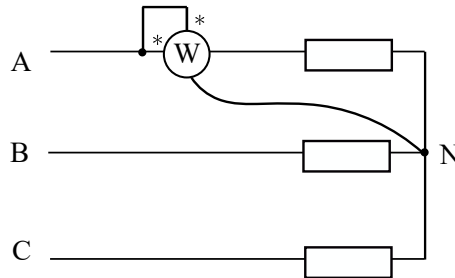

$$W = I_A U_{AN} \cos(\underline{U}_{AN} \underline{I}_A) = U_{Ph} I_{Ph} \cos \varphi = \frac{P}{3} \quad (62)$$

### 6.3 Measure of the reactive power of a three-phase system with one wattmeter

The reactive power of a balanced three phase load can be measure with one wattmeter, even if there is not neutral point or there is no access to it. The wattmeter must be connected to

measure the current flowing through one phase and the voltage drop between the other two phases:

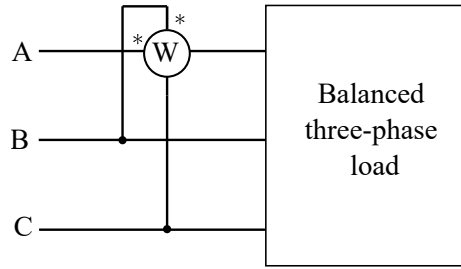

The wattmeter of the figure measures:

$$W = U_{BC} I_A \cos(\underline{U}_{BC} \underline{I}_A) \quad (63)$$

The value of the angle  $\underline{U}_{BC} \underline{I}_A$  can be determined using a phasor diagram. As can be seen in the phasor diagram provided below, the angle equals  $90^\circ - \varphi$  for an inductive load. If the load is capacitive, the current leads the voltage by  $\varphi$ , and the angle  $\underline{U}_{BC} \underline{I}_A$  is  $90^\circ + \varphi$ :

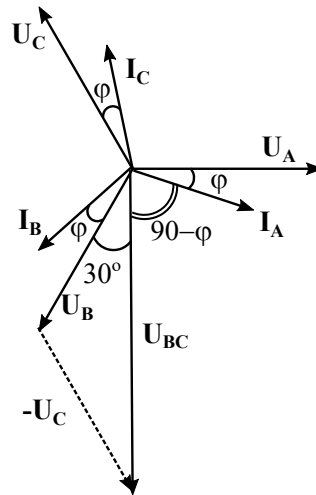

$$W = U_L I_L \cos(\underline{U}_{BC} \underline{I}_A) = U_L I_A \cos(90^\circ - \varphi) = U_L I_A \sin(\varphi) = \frac{Q}{3} \quad (64)$$

#### 6.4 The two wattmeters method

The two wattmeters method allows us to measure the active and reactive power of balanced three-phase systems. Two wattmeters  $W_1$  and  $W_2$  are connected as shown in the following diagram:

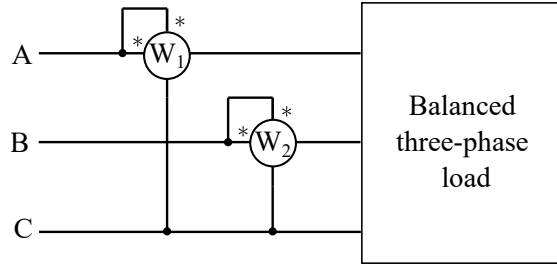

The wattmeters measure:

$$W_1 = U_{AC} I_A \cos(\underline{U}_{AC} \underline{I}_A) \quad (65)$$

$$W_2 = U_{BC} I_B \cos(\underline{U}_{BC} \underline{I}_B) \quad (66)$$

The values of the angles can be found using the phasor diagram:

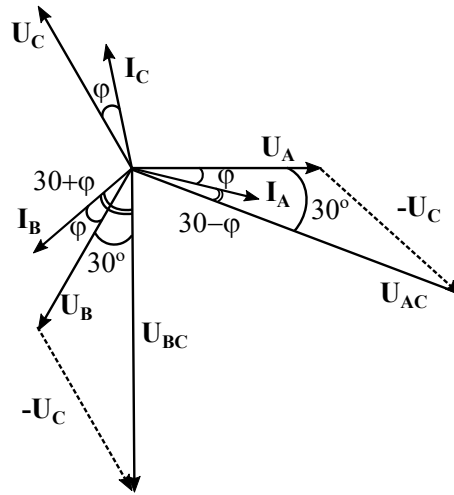

$$W_1 = U_L I_L \cos(\underline{U}_{AC} \underline{I}_A) = U_L I_L \cos(30 - \varphi) = U_L I_L \left( \frac{\rho_3}{2} \cos \varphi + \frac{1}{2} \sin \varphi \right) \quad (67)$$

$$W_2 = U_L I_L \cos(\underline{U}_{BC} \underline{I}_B) = U_L I_L \cos(30 + \varphi) = U_L I_L \left( \frac{\rho_3}{2} \cos \varphi - \frac{1}{2} \sin \varphi \right) \quad (68)$$

The active and reactive power of the three phase system can be obtained as the sum and the difference of the readings of the two wattmeters.

$$W_1 + W_2 = \frac{\rho_3}{3} U_L I_L \cos \varphi = P \quad (69)$$

$$W_1 - W_2 = U_L I_L \sin \varphi = \frac{Q}{3} \quad (70)$$