

# Electrical power engineering fundamentals

Partial exam. 25th November 2020

**Instructions** Solve the problems using the methods indicated in the problem statements and write a summary of your results in this paper. Only the solutions obtained with these methods will be graded.

Name.....

## DC Circuits

Given that the values of the parameters are  $R_1 = 1\Omega$ ,  $R_2 = 2\Omega$ ,  $R_3 = 3\Omega$ ,  $R_4 = 4\Omega$ ,  $R_5 = 5\Omega$ ,  $u_{g1} = 1V$ ,  $i_{g2} = 2A$ ,  $u_{g3} = 3V$ ,  $u_{g4} = 4V$

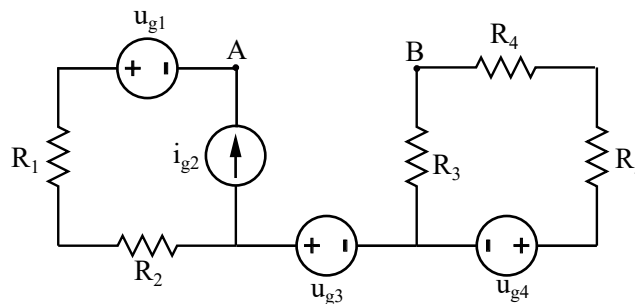

a) Find the Thevenin equivalent in the circuit of the figure on the left between A and B **including all the elements of the circuit in it**. Draw the equivalent indicating the obtained values for the parameters. (6.5 points)

b) Calculate the value of the resistor  $R_L$  that must be connected between A and B to extract the maximum power from the circuit. Calculate the power absorbed by the resistor. (3.5 points)

## Solution

a) First We calculate Thevenin voltage by the open circuit analysis

We apply second Kirchhoff law to the two mesh of the circuit and find the currents:

$$i_1 = i_{g2} = 2A$$

$$i_2 = \frac{u_{g4}}{R_3 + R_4 + R_5} = 0.33A$$

$$u_{th} = u_{AB} = u_{i_{g2}} + u_{g3} - u_{R3} = -u_{g1} + (R_1 + R_2) \cdot i_1 + u_{g3} - R_3 \cdot i_2 = 7V$$

Then we calculate Thevenin resistance passivizing the circuit:

$$R_{th} = R_1 + R_2 + (R_3 || (R_4 + R_5)) = 5.25\Omega$$

b) Maximum power transfer  $R_L = R_{th} = 5.25\Omega$

Power absorbed by  $R_L$ :

$$i_L = \frac{u_{th}}{R_{th} + R_L} = 0.67A$$

$$P_{R_L} = R_L \cdot i_L^2 = 2.33W$$

### AC circuits

Given that the values of the parameters are  $R = 4$ ,  $L = 0.1H$ ,  $C = 25mF$

$$i_{g1}(t) = \sqrt{2} \cdot 10 \cdot \cos 10tA \quad u_{g2}(t) = \sqrt{2} \cdot 2 \cdot \cos(10t + 90)A$$

$$u_{g3}(t) = \sqrt{2} \cdot 15 \cdot \cos 10tV \quad i_{g4}(t) = \sqrt{2} \cdot \cos(10t - 90)A$$

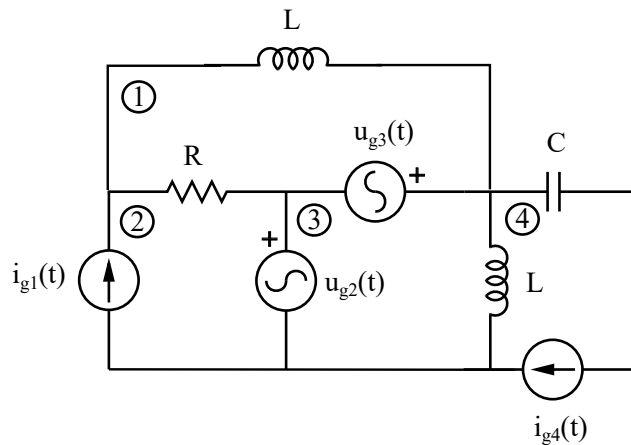

a) Write the mesh equations of the circuit. (Label the mesh currents with the names provided in the figure and take the mesh currents in clockwise direction). (3.5 points)

b) Solve the equations and find the mesh currents (write phasors mesh currents below) (2.5 points)

c) Do a power balance of the circuit and write a summary of your results below. (4 points)

### Solution

Circuit in the frequency domain  $\omega = 10rad/s$

$$Z_R = 4\Omega \quad Z_L = j\Omega \quad Z_C = -4j\Omega$$

$$\underline{I}_{g1} = 10A \quad \underline{U}_{g2} = 2jV \quad \underline{U}_{g3} = 15V \quad \underline{I}_{g4} = -jA$$

Mesh equations:

$$\underline{I}_1 \cdot Z_L + \underline{U}_{g3} + Z_R \cdot (\underline{I}_1 - \underline{I}_2) = 0$$

$$\begin{aligned}\underline{\mathbf{I}}_2 &= \underline{\mathbf{I}}_{g1} \\ -\underline{\mathbf{U}}_{g2} - \underline{\mathbf{U}}_{g3} + Z_L \cdot (\underline{\mathbf{I}}_3 - \underline{\mathbf{I}}_4) &= 0 \\ \underline{\mathbf{I}}_4 &= \underline{\mathbf{I}}_{g4}\end{aligned}$$

b) Mesh currents:

$$\underline{\mathbf{I}}_1 = 5.88 - 1.47j = 6.06\angle-14.03A \quad \underline{\mathbf{I}}_2 = 10A \quad \underline{\mathbf{I}}_3 = 2 - 16j = 16.12\angle-82.87A \quad \underline{\mathbf{I}}_4 = -jA$$

c) Power balance

$$\begin{aligned}P_R &= Z_R \cdot |\underline{\mathbf{I}}_1 - \underline{\mathbf{I}}_2|^2 = 76.47W \\ Q_L &= X_L \cdot |\underline{\mathbf{I}}_1|^2 + X_L \cdot |\underline{\mathbf{I}}_3 - \underline{\mathbf{I}}_4|^2 = 36.76 + 229 = 261var \\ Q_C &= X_C \cdot |\underline{\mathbf{I}}_4|^2 = -4var\end{aligned}$$

$$S_{loads} = P_R + j \cdot (Q_L + Q_C) = 76.47 + j261.76jVA$$

Sources:

$$\begin{aligned}S_{g1} &= \underline{\mathbf{U}}_{g1} \cdot \underline{\mathbf{I}}_{g1}^* = 164.7 + 78.82j = 182.6\angle25.57VA \\ \underline{\mathbf{U}}_{g1} &= Z_R \cdot (\underline{\mathbf{I}}_1 - \underline{\mathbf{I}}_2) + \underline{\mathbf{U}}_{g2} = 16.47 + 7.9j = 18.26\angle25.57V\end{aligned}$$

$$S_{g2} = \underline{\mathbf{U}}_{g2} \cdot (\underline{\mathbf{I}}_3 - \underline{\mathbf{I}}_2)^* = -32 - 16j = 37.78\angle-153.4$$

$$S_{g3} = \underline{\mathbf{U}}_{g2} \cdot (\underline{\mathbf{I}}_3 - \underline{\mathbf{I}}_1)^* = -58.2 + 217.9j = 225.59\angle105VA$$

$$\begin{aligned}S_{g4} &= \underline{\mathbf{U}}_{g4} \cdot \underline{\mathbf{I}}_{g4}^* = 2 - 19j = 19.1\angle-84VA \\ \underline{\mathbf{U}}_{g4} &= Z_L \cdot (\underline{\mathbf{I}}_4 - \underline{\mathbf{I}}_3) + Z_C \cdot \underline{\mathbf{I}}_4 = -19 - 2j = 19.1\angle-174V\end{aligned}$$

$$S_g = S_1 + S_2 + S_3 + S_4 = 76.47 + 261.76jVA$$