

Electrical Power Engineering Fundamentals. 3rd partial exam. Dec 2018

Name:.....

In the following system, the generator supplies 5000 W and 3500 var to the system; the wattmeter (W) measures 2000 W and the voltmeter V_1 measures 400 V

Considering that the sequence of the system is positive. Calculate:

- The reactive power absorbed by load 2 and its power factor.
- The phasor line-current \underline{I}_R taking the phase voltage \underline{U}_{RN} as phase origin and the power factor of the generator.
- The measure of the voltmeter V_2
- The active power, reactive power and power factor of load 1 and its impedance per phase $Z_{1\phi}$.
- Explain how to compensate the power factor of the system to optimize its efficiency. (Calculate what elements should be connected indicating their connection form and the connection point. Justify your answer as clearly as possible. Consider That the voltage supplied to the load remains constant.)
- Calculate the measure of V_1 and W after the compensation.

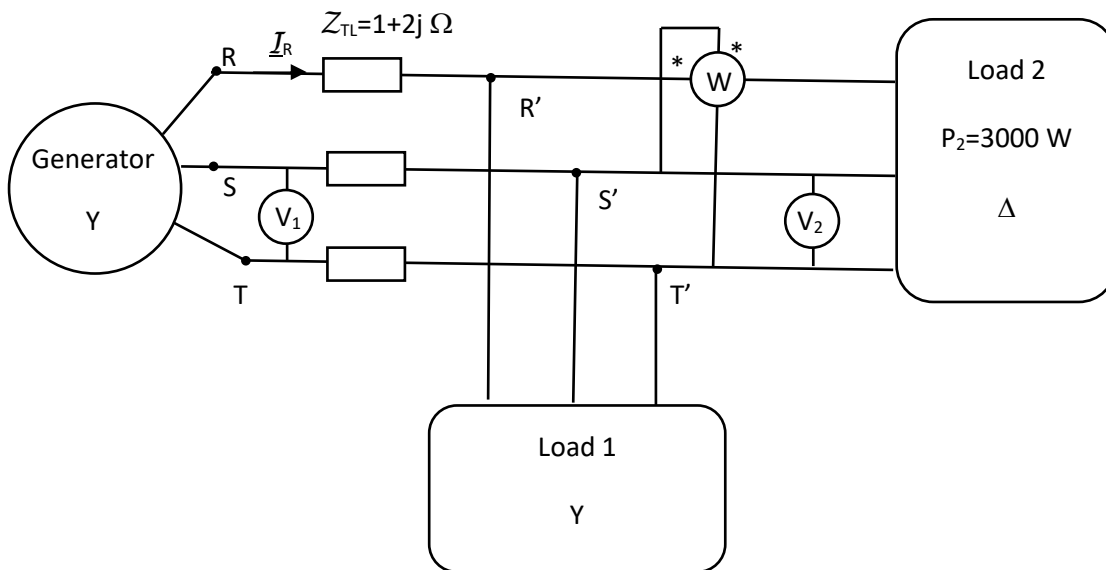

NUMERIC ANSWERS:

- a) $Q_2 =$ p.f.2 =
- b) $\underline{I}_R =$ p.f.g = c) $V_2 =$
- d) $Q_1 =$ $P_1 =$ p.f.1 = $Z_{1\phi} =$
- f) $V_1' =$ $V_2' =$ $W' =$